

PROJECTION TELEVISION OWNER'S GUIDE

VS-50805

VS-60805



WT-46805

WS-55805

WS-55905

WS-65905

WS-73905



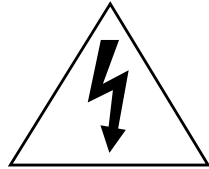

CAUTION

RISK OF ELECTRIC SHOCK
DO NOT OPEN



CAUTION: TO REDUCE THE RISK OF ELECTRIC SHOCK, DO NOT REMOVE COVER (OR BACK).
NO USER-SERVICEABLE PARTS INSIDE.
REFER SERVICING TO QUALIFIED SERVICE PERSONNEL.

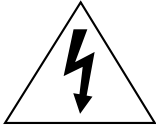

The lightning flash with arrowhead symbol within an equilateral triangle is intended to alert the user to the presence of uninsulated “dangerous voltage” within the product’s enclosure that may be of sufficient magnitude to constitute a risk of electric shock.



The exclamation point within an equilateral triangle is intended to alert the user to the presence of important operating and maintenance (servicing) instructions in the literature accompanying the appliance.

Warning: To avoid permanently imprinting a fixed image onto your TV screen, please do not display the same stationary images on the screen for more than 15% of your total TV viewing in one week. Examples of stationary images are letterbox top/bottom bars from DVD disc or other video sources, side bars when showing standard TV pictures on widescreen TV’s, stock market reports, video game patterns, station logs, web sites or stationary computer images. Such patterns can unevenly age the picture tubes causing permanent damage to the TV. Please see page 56 for a detailed explanation.

Note: This equipment has been tested and found to comply with the limits for a Class B digital device, pursuant to part 15 of the FCC Rules. These limits are designed to provide reasonable protection against harmful interference in a residential installation. This equipment generates, uses and can radiate radio frequency energy and, if not installed and used in accordance with the instructions, may cause harmful interference to radio communications. However, there is no guarantee that interference will not occur in a particular installation. If this equipment does cause harmful interference to radio or television reception, which can be determined by turning the equipment off and on, the user is encouraged to try to correct the interference by one or more of the following measures:

- Reorient or relocate the receiving antenna
- Increase the separation between the equipment and receiver
- Connect the equipment into an outlet on a circuit different from that to which the receiver is connected
- Consult the dealer or an experienced radio/TV technician for help

Changes or modifications not expressly approved by Mitsubishi could void the user’s authority to operate this equipment.

WARNING:

TO REDUCE THE RISK OF FIRE OR ELECTRIC SHOCK, DO NOT EXPOSE THIS APPLIANCE TO RAIN OR MOISTURE.

CAUTION:

TO PREVENT ELECTRIC SHOCK, MATCH WIDE BLADE OF PLUG TO WIDE SLOT, FULLY INSERT.

NOTE TO CATV SYSTEM INSTALLER:

THIS REMINDER IS PROVIDED TO CALL THE CATV SYSTEM INSTALLER’S ATTENTION TO ARTICLE 820-40 OF THE NEC THAT PROVIDES GUIDELINES FOR PROPER GROUNDING AND, IN PARTICULAR, SPECIFIES THAT THE CABLE GROUND SHALL BE CONNECTED TO THE GROUNDING SYSTEM OF THE BUILDING, AS CLOSE TO THE POINT OF CABLE ENTRY AS PRACTICAL.

Contents

Important Safeguards _____	5
Instructions on safety and proper handling of your Mitsubishi television	
Special Features _____	7
Distinctive features, items included with your Mitsubishi television and hookup guidelines	
Shortcuts _____	8
A quick reference list	
Connections _____	9
Basic hookups to an antenna, cable, components, IR emitter and HDTV receiver	
Remote Control Functions _____	18
Features of the remote control, programming to work with other audio and video products, explanation of buttons, controlling the sleep timer	
The ▶ViewPoint® Menu System _____	25
Explanation of the on-screen menu system and all menu screens and how to use the menus	
Special Remote Control Functions _____	59
Using the remote with other products, using the PIP (Picture-in-Picture), Side-by-side and POP (Picture-outside-Picture) features, Formats, Mitsubishi's Active AV Network and Home Theater IR system control	
Control Panel Functions _____	68
Explanation of the front control panel buttons and the back panel terminals	
Troubleshooting _____	73
Common problems, notes on caring and cleaning for your Mitsubishi television and how to obtain service	
Appendices _____	77
Diamond Shield™ removal and installation, remote control programming codes, bypassing the parent lock, INPUT-3 component video and HDTV video connection compatibility	

Important Safeguards

Please read all these instructions regarding your television set and retain for future reference. Follow all warnings and instructions marked on the television.

1. Read, Retain and Follow Instructions

Read all safety and operating instructions before operating the appliance. Retain the safety and operating instructions for future reference. Follow all operating and use instructions.

2. Heed Warnings

Adhere to all warnings on the appliance and in the operating instructions.

3. Cleaning

Unplug this TV receiver from the wall outlet before cleaning. Do not use liquid or aerosol cleaners. Cleaners can permanently damage the cabinet or screen. Use a damp cloth for cleaning.

4. Attachments and Equipment

Never add any attachments and/or equipment without approval of the manufacturer as such additions may result in the risk of fire, electric shock or other personal injury.

5. Water and Moisture

Do not use this TV receiver where contact with or immersion in water is possible. Do not use near bath tubs, wash bowls, kitchen sinks, laundry tubs, swimming pools, etc.

6. Accessories

Do not place this TV receiver on an unstable cart, stand, tripod, bracket, or table. The TV receiver may fall, causing serious injury to a child or adult, and serious damage to the appliance. Use only with a cart, stand, tripod, bracket, or table recommended by the manufacturer, or sold with the TV receiver. Any mounting of the appliance should follow the manufacturer's instructions, and should use a mounting accessory recommended by the manufacturer.



An appliance and cart combination should be moved with care. Quick stops, excessive force, and uneven surfaces may cause the appliance and cart combination to overturn.

7. Ventilation

Slots and openings in the cabinet are provided for ventilation and to ensure reliable operation of the TV receiver and to protect it from overheating. Do not block these openings or allow them to be blocked by placing the TV receiver on a bed, sofa, rug, or other similar surface. Nor should it be placed over a radiator or heat register. If the TV receiver is to be placed in a rack or bookcase, ensure that there is adequate ventilation and that the manufacturer's instructions have been adhered to.

8. Power Source

This TV receiver should be operated only from the type of power source indicated on the marking label. If you are not sure of the type of power supplied to your home, consult your appliance dealer or local power company.

9. Grounding or Polarization

This TV receiver is equipped with a polarized alternating current line plug having one blade wider than the other. This plug will fit into the power outlet only one way. If you are unable to insert the plug fully into the outlet, try reversing the plug. If the plug should still fail to fit, contact your electrician to replace your obsolete outlet. Do not defeat the safety purpose of the polarized plug.

10. Power-Cord Protection

Power-supply cords should be routed so that they are not likely to be walked on or pinched by items placed upon or against them, paying particular attention to cords at plugs, convenience receptacles, and the point where they exit from the appliance.

11. Lightning

For added protection for this TV receiver during a lightning storm, or when it is left unattended and unused for long periods of time, unplug it from the wall outlet and disconnect the antenna or cable system. This will prevent damage to the TV receiver due to lightning and power-line surges.

12. Power Lines

An outside antenna system should not be located in the vicinity of overhead power lines or other electric light or power circuits, or where it can fall into such power lines or circuits. When installing an outside antenna system, extreme care should be taken to keep from touching such power lines or circuits as contact with them might be fatal.

13. Overloading

Do not overload wall outlets and extension cords as this can result in a risk of fire or electric shock.

14. Object and Liquid Entry

Never push objects of any kind into this TV receiver through openings as they may touch dangerous voltage points or short-out parts that could result in a fire or electric shock. Never spill liquid of any kind on the TV receiver.

15. Outdoor Antenna Grounding

If an outside antenna or cable system is connected to the TV receiver, be sure the antenna or cable system is grounded so as to provide some protection against voltage surges and built-up static charges.

Section 810 of the National Electrical Code, ANSI/NFPA No. 70-1984, provides information with respect to proper grounding of the mast and supporting structure, grounding of the lead in wire to an antenna discharge unit, size of grounding conductors, location of antenna discharge unit, connection to grounding electrodes, and requirements for the grounding electrode.

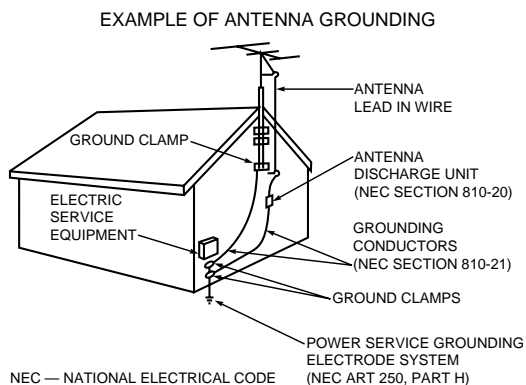

16. Servicing

Do not attempt to service this TV receiver yourself as opening or removing covers may expose you to dangerous voltage or other hazards. Refer all servicing to qualified service personnel.

17. Damage Requiring Service

Unplug this TV receiver from the wall outlet and refer servicing to qualified service personnel under the following conditions:

- (a) When the power-supply cord or plug is damaged.
- (b) If liquid has been spilled, or objects have fallen into the TV receiver.
- (c) If the TV receiver has been exposed to rain or water.
- (d) If the TV receiver does not operate normally by following the operating instructions, adjust only those controls that are covered by the operating instructions as an improper adjustment of other controls may result in damage and will often require extensive work by a qualified technician to restore the TV receiver to its normal operation.
- (e) If the TV receiver has been dropped or the cabinet has been damaged.
- (f) When the TV receiver exhibits a distinct change in performance — this indicates a need for service.

18. Replacement Parts

When replacement parts are required, be sure the service technician has used replacement parts specified by the manufacturer or have the same characteristics as the original part. Unauthorized substitutions may result in fire, electric shock or other hazards.

19. Safety Check

Upon completion of any service or repairs to this TV receiver, ask the service technician to perform safety checks to determine that the TV receiver is in safe operating condition.

Special Features

- ◇ **HDTV Upgradeable** - with the use of an optional HDTV receiver, your television can display High Definition pictures
- ◇ **Wide Screen Television** - displays pictures in a widescreen 16:9 aspect ratio for models WT-46805, WS-55805, WS-55905, WS-65905 and WS-73905
- ◇ **Wide Screen Formats** - for displaying anamorphic DVDs on models VS-50805 and VS-60805
- ◇ **IRIS™** - room sensor that automatically adjusts brightness and contrast
- ◇ **Multibrand Remote Control** - use one remote control for many audio/video components

Unpacking Your TV

The following items are included with your new TV:

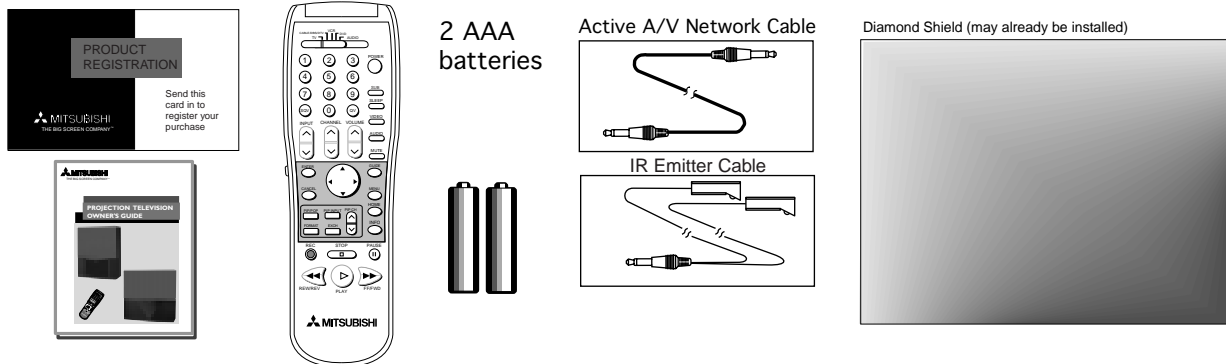

Choosing a Hookup

The connections shown in this book are general. Cable systems as well as individual audio and/or video components can vary from those shown here. The first diagrams show basic connections to antenna or cable systems. After you have completed these, you can then connect any additional components (stereo, DVD, AV receiver, etc.).

IMPORTANT

To maximize your system for its best performance, your dealer can help you customize hookups and sell you any additional connection accessories that may be needed for your individual equipment.

Shortcuts

- ◇ **Connecting the TV to an antenna or wall outlet cable - page 9**
- ◇ **Connecting an HD-1080 receiver - page 15**
- ◇ **Remote control functions - pages 18-19**
- ◇ **Menu screen summaries - pages 26-28**
- ◇ **Setup Menu - pages 29-35**
- ◇ **Setting the V-Chip parent lock - pages 44-48**
- ◇ **Using PIP and POP features - page 60**
- ◇ **Troubleshooting - page 73**
- ◇ **DVD component video and HDTV video connection compatibility - page 83**

Connections

TV to Antenna or Wall Outlet Cable

Separate UHF and VHF antennas

1. Connect the UHF and VHF antenna leads to the UHF/VHF combiner.
2. Push the combiner onto ANT-A on the TV back panel.

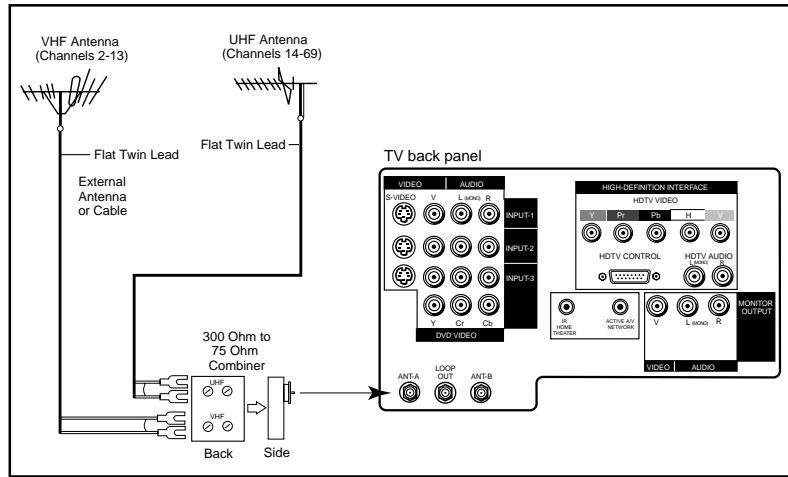

Twin lead antenna or wall outlet cable

For antenna with twin flat leads

1. Connect the 300 ohm twin leads to the transformer.
2. Push the 75 ohm side of the transformer onto ANT-A on the TV back panel.

For cable or antenna with coaxial lead

Connect the incoming cable to ANT-A on the TV back panel.

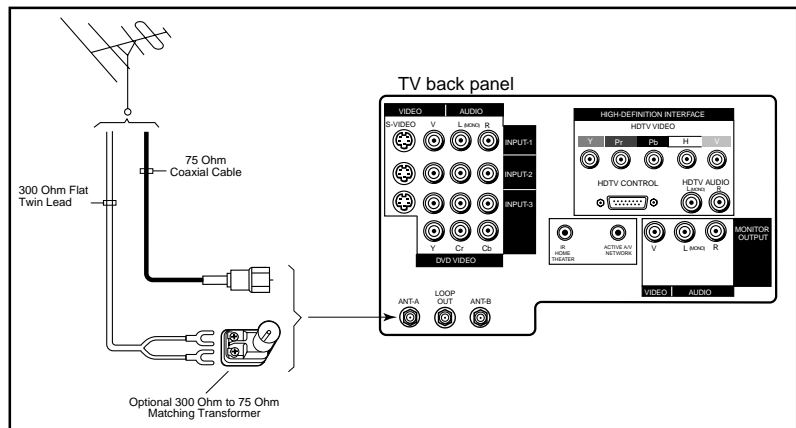

Connection of TV to Cable Box

1. Connect the incoming cable to ANT-A on the TV back panel.
2. Connect two coaxial cables as follows:
 - One from LOOP-OUT on the TV back panel to IN on the back of the cable box.
 - One from OUT on the back of the cable box to ANT-B on the TV back panel.

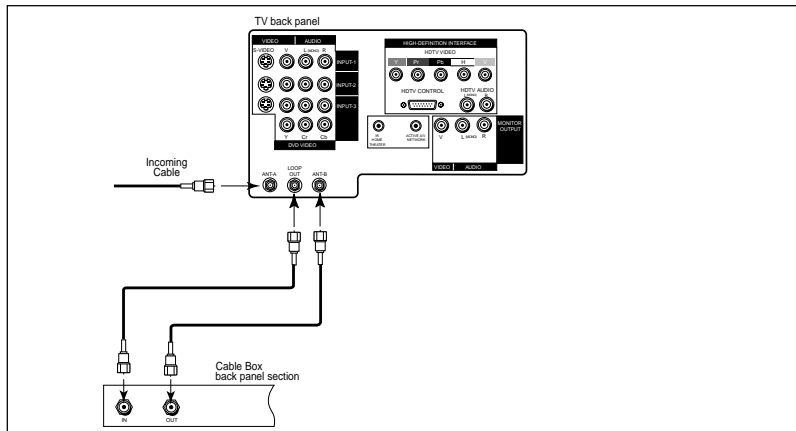

Connection of TV to VCR and Cable Box

1. Connect the incoming cable to ANT-A on the TV back panel.
2. Connect three coaxial cables as follows:
 - One from LOOP-OUT on the TV back panel to IN on the back of the cable box.
 - One from OUT on the back of the cable box to ANTENNA IN on the VCR back panel.
 - One from ANTENNA OUT on the VCR back panel to ANT-B on the TV back panel.

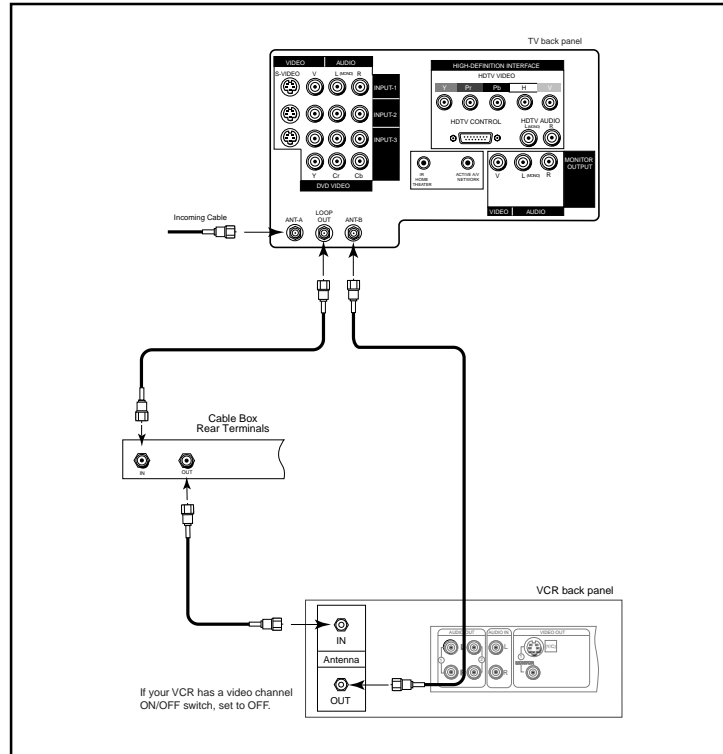

Audio Video Connections

1. Connect a video cable from VIDEO, OUT on the VCR back panel to VIDEO, INPUT-1 or INPUT-2 on the TV back panel.
 - If you have a S-VHS VCR, follow the same steps, using the S-Video terminals on the VCR and TV.
2. Connect a set of audio cables from AUDIO, OUT on the VCR back panel to AUDIO, INPUT-1 or INPUT-2 on the TV back panel. The red cable connects to the R (right) channel and the white cable connects to the L (left). If your VCR is non-stereo, connect only the L (left) cable.

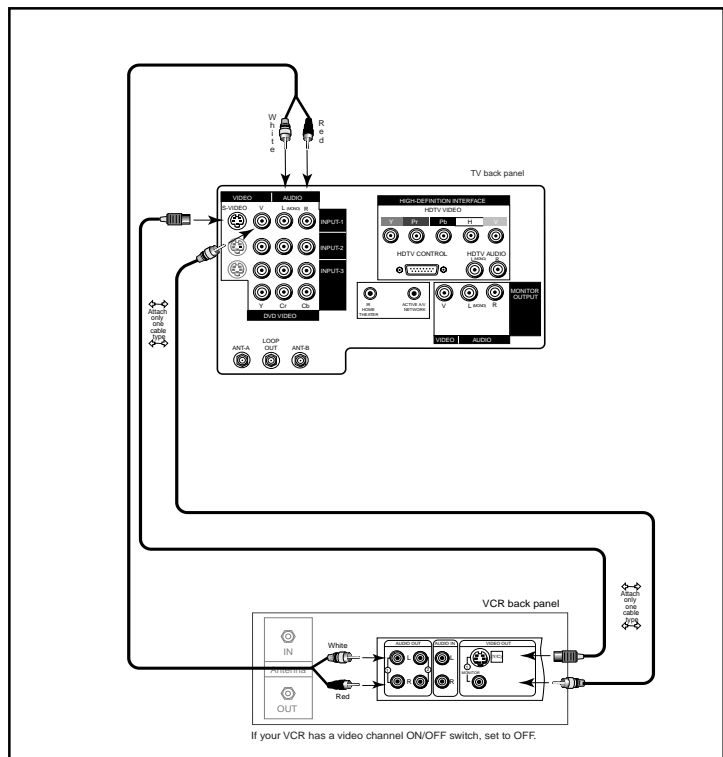

Connection of TV to VCR and Antenna or Wall Outlet Cable

Antenna/Cable Connections

1. Connect the incoming cable to ANT-A on the TV back panel.
2. Connect two coaxial cables as follows:
 - One from LOOP-OUT on the TV back panel to ANTENNA IN on the VCR back panel.
 - One from VCR back panel ANTENNA OUT to ANT-B on the TV back panel.

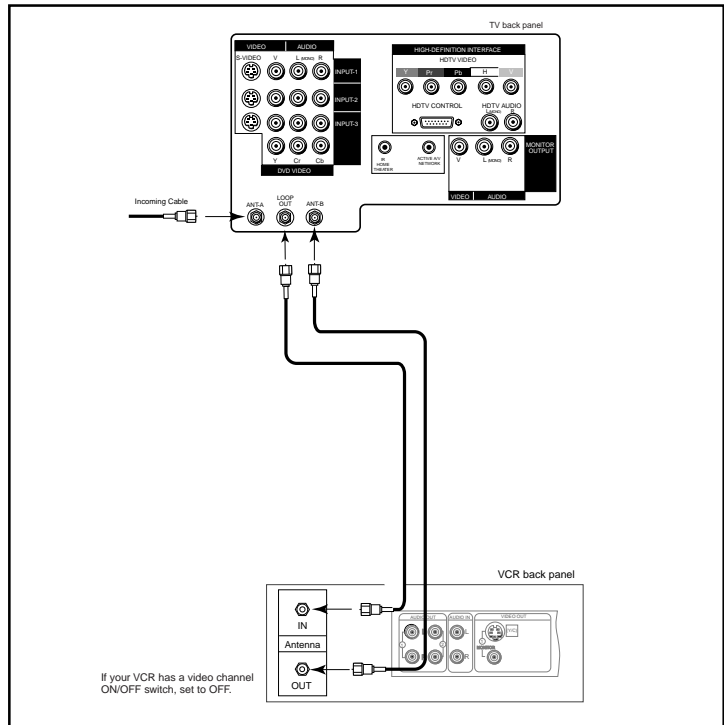

Audio/Video Connections

1. Connect a video cable from VIDEO, OUT on the VCR back panel to VIDEO, INPUT-1 or INPUT-2 on the TV back panel (INPUT-1 shown).
- If you have a S-VHS VCR, follow the same steps, using the S-Video terminals on the VCR and TV.
2. Connect a set of audio cables from AUDIO OUT on the VCR back panel to AUDIO, INPUT-1 or INPUT-2 on the TV back panel. The red cable connects to the R (right) channel and the white cable connects to the L (left). If your VCR is non-stereo, only connect the L (left) cable (Input-1 shown).

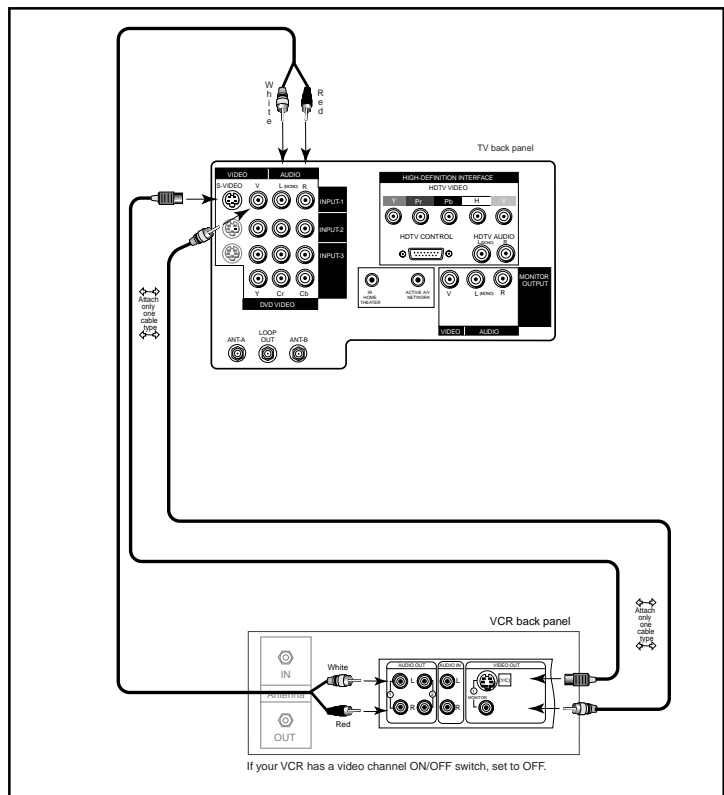

Connection of TV to Stereo Audio System

1. Connect the audio cables from AUDIO, MONITOR OUTPUT on the TV back panel to TV IN or AUX IN terminals on the back of the audio system. The red cable connects to the R (right) channel and the white cable connects to the L (left) channel.
2. Turn off the TV's speakers through the AV CONNECTION Menu (pages 32-34).
3. Set the audio system's input to the TV or AUX position to hear the TV's audio through your stereo system.

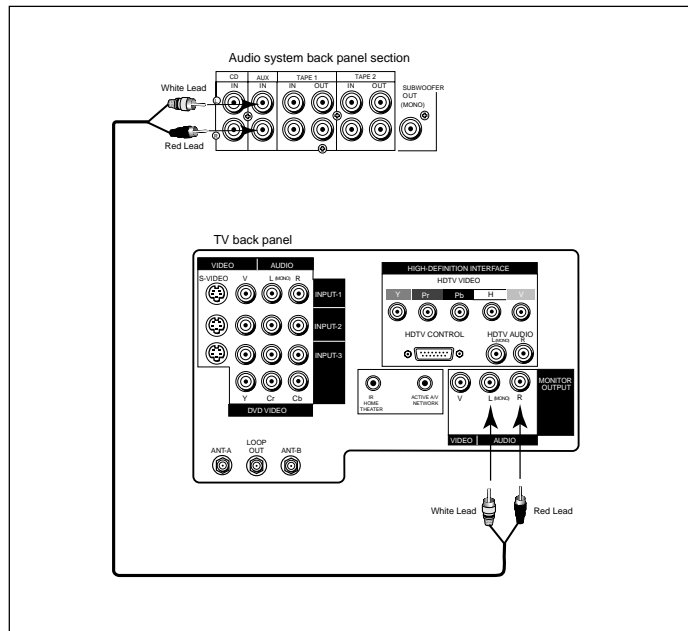

Connection of TV to the Active A/V Network

To control your Mitsubishi audio and/or video products with one remote control

Connect the A/V network cable from ACTIVE A/V NETWORK on the TV back panel to IN on the back of a Mitsubishi VCR that has A/V network terminal.

Turn the ACTIVE A/V NETWORK on through the AV CONNECTION menu (pages 32-34).

IMPORTANT

Check the Owner's Guide of your added Mitsubishi components to ensure the best possible connections.

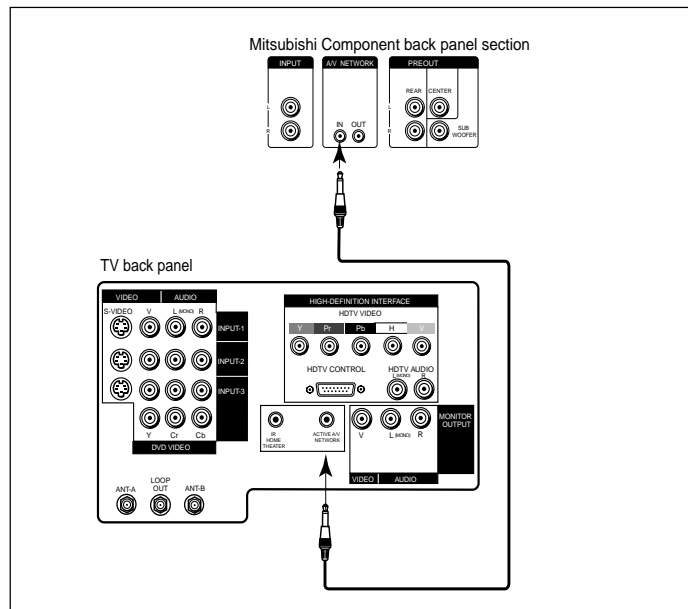

Connection of TV to AV Receiver

1. Connect a video cable from VIDEO, MONITOR OUT on the back of the AV Receiver to VIDEO, INPUT-1 on the TV back panel using a VIDEO cable.
2. Connect a video cable from VIDEO, MONITOR OUTPUT on the TV back panel to VIDEO TV IN on the back of the AV Receiver.
3. Connect a set of audio cables from AUDIO, MONITOR OUTPUT on the TV back panel to AUDIO TV IN on the back of the AV Receiver. The red cable connects to the R (right) channel and the white cable connects to the L (left) channel.

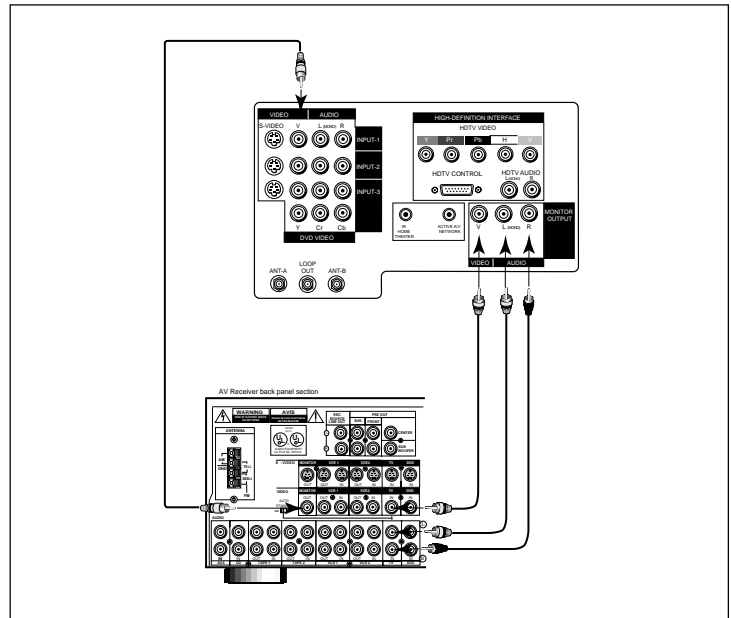

Connection of TV to a Mitsubishi AV Receiver Infrared Emitter (IR) for Home Theater Control

1. Connect the IR emitter cable to IR HOME THEATER on the back of the television.
2. Place the IR emitter cable under or along side of the AV receiver. Place the IR lens directly in front of the infrared location of the AV receiver. Infrared locations are usually on the front glass section of the receiver.
3. Place the unused transmitter in an out-of-the-way location.
4. For permanent installation of the IR emitter cable, use the included adhesive tape to secure the bottom of the emitter to the anchoring object you choose.

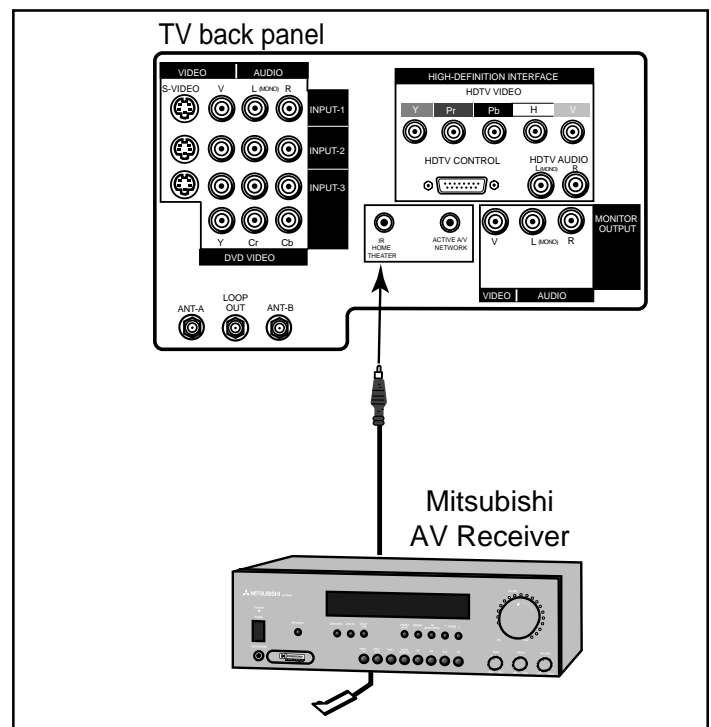

IMPORTANT

See pages 67-68 for details on using the TV's IR emitter to control a Mitsubishi AV receiver.

Connection of TV to DVD with Component Video Outputs

1. Connect the Component Video cables from VIDEO OUT on the back of the DVD player to DVD VIDEO input on the TV back panel, matching the correct components:
 - Y to Y,
 - Cr to Cr,
 - Cb to Cb.
2. Connect a set of audio cables from AUDIO OUT on the back of the DVD player to AUDIO, INPUT-3 on the TV back panel. The red cable connects to the R (right) channel and the white cable connects to the L (left) channel.

IMPORTANT

1. See Appendix 4 for component video signal compatibility information.

2. For Digital Audio connections, see the Owner's Guides of your DVD Player and AV receiver.

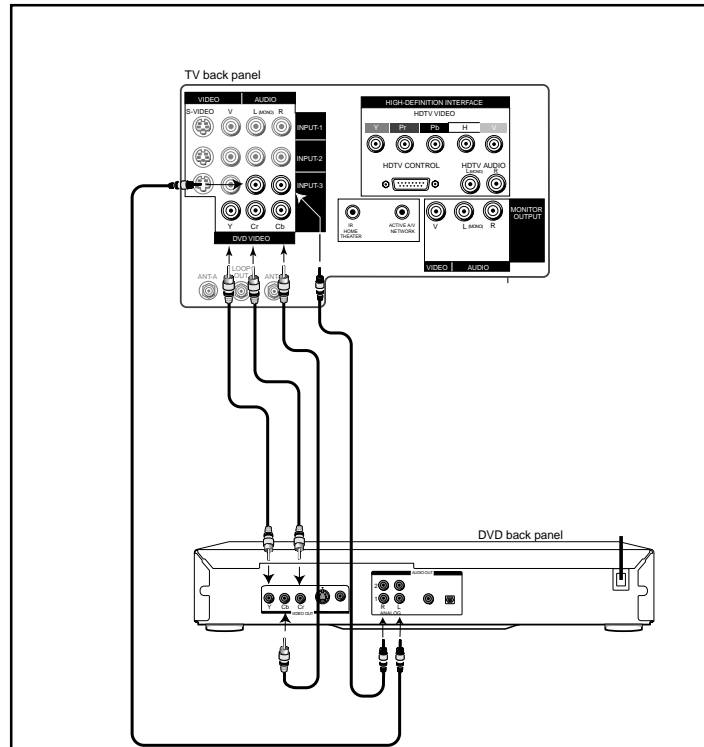

Connectors for TV and Cable to HDTV Receiver

The TV back panel has 5 RCA type connectors, for the HDTV connection. The back panel of your HDTV receiver may use RCA type connectors or BNC type connectors for its connection. If your HDTV receiver comes with BNC type connections, you will have to purchase BNC to RCA adaptors, to connect the TV to the HDTV receiver. These adaptors should be available at electronics supply stores.

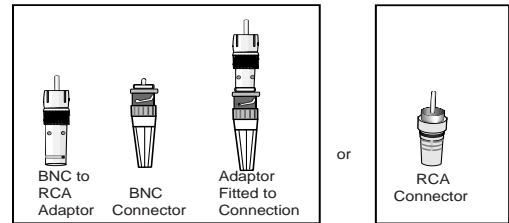

Connection of TV and Cable to Mitsubishi's HD-1080 Receiver

1. Connect the outside antenna to ANT on the optional HD-1080 receiver.
2. Connect the incoming cable to ANT-A on the television back panel.
3. Connect the HDTV cable to HDTV CONTROL on the TV back panel and the HDTV receiver back panel.
4. OPTIONAL: To use TV speakers, connect the audio cables to HDTV L(left) and R(right) AUDIO on the HDTV receiver and the television back panel.
5. Connect the color coded BNC cables to HDTVVIDEO on the HDTV receiver. After fitting the BNC to RCA adaptors onto the BNC cables, connect them to the television back panel. The sequence for connecting the color cables is:

Y = green cable
 Pr = red cable
 Pb = blue cable
 H = white cable
 V = yellow cable

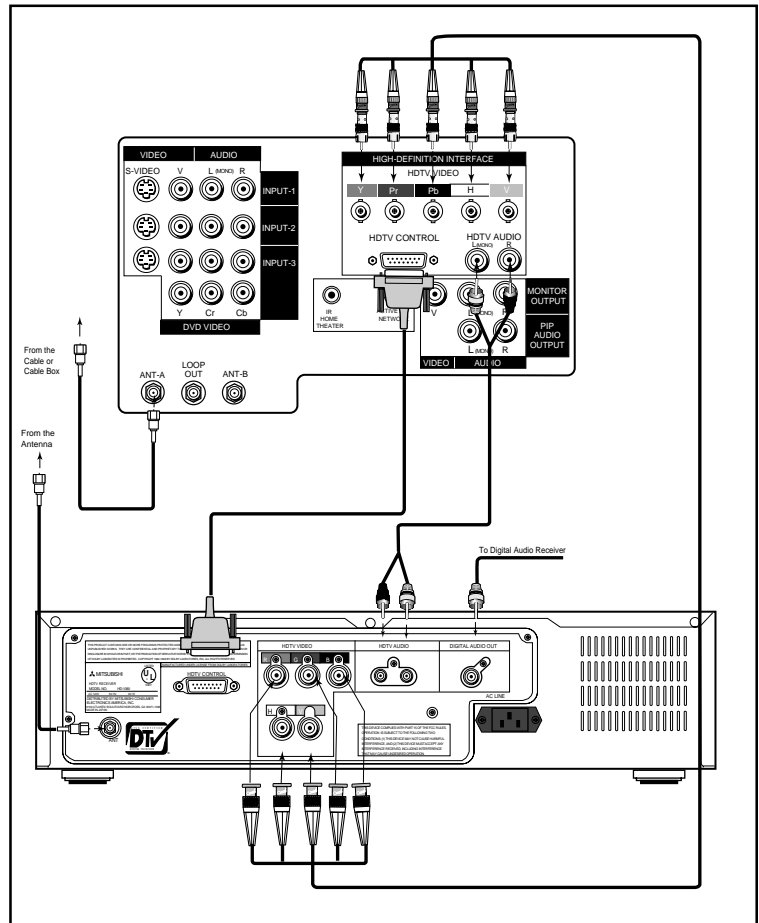

IMPORTANT

For Digital Audio connections, see the Owner's Guides of your HDTV receiver.

Connection of TV and Cable to HDTV Receiver

Industry Standards for HDTV RGB signals systems, synchronizations and signal strengths have not been established. These inputs will not be compatible with all HDTV receivers that offer RGB. If your HDTV receiver offers both a HDTV component (Y, Pr, Pb) video system and a HDTV RGB video signals, Mitsubishi suggests you use the HDTV component video system.

IMPORTANT

If a HD-1080 receiver was connected and you change to another DTV receiver, you must turn the Power off, then unplug and plug in the television to allow the new HD receiver to work correctly.

Connection of TV and Cable to HDTV Receiver with Component Video Connections

1. Connect the outside antenna to ANT on the optional HDTV receiver.
2. Connect the incoming cable to ANT-A on the television back panel.
3. Connect the RCA type cables or the fitted RCA/BNC cables to Y, Pr and Pb on the HDTV receiver.
4. Connect the RCA type cables or the fitted RCA/BNC cables to Y, Pr, and Pb on the TV back panel. You must also select the DTV Assign Input setting (page 35) of YPrPb.
5. OPTIONAL: To use TV speakers, connect the L(left) and R(right) audio cables to the optional HDTV receiver and to HDTV AUDIO on the television back panel.

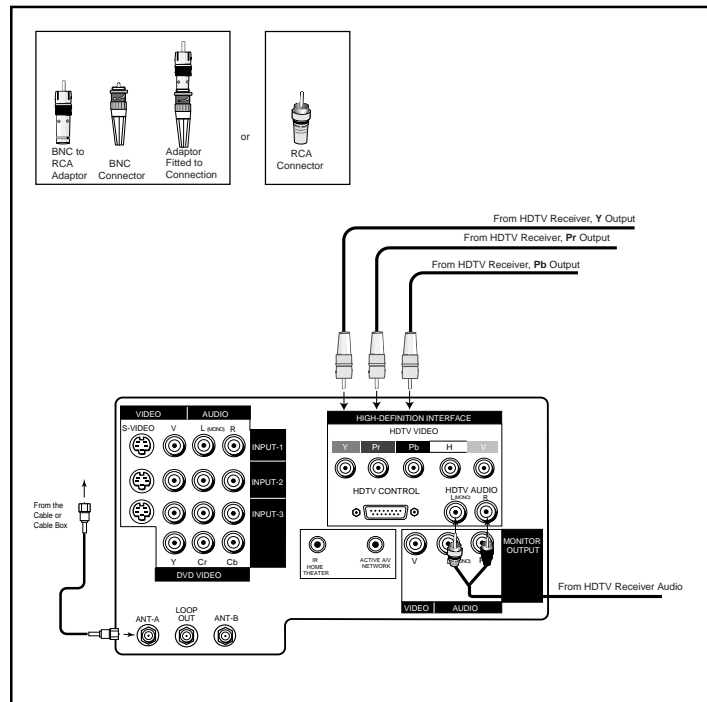

IMPORTANT

1. See Appendix 4 for video signal compatibility information.
2. For Digital Audio connections, see the Owner's Guides of your HDTV receiver and AV receiver.

Connection of TV and Cable to HDTV Receiver with RGB Connections

1. Connect the outside antenna to ANT on the optional HDTV receiver.
2. Connect the incoming cable to ANT-A on the television back panel.
3. Connect the RGB cables to the HDTV receiver and the television back panel. The sequence for connecting the cables is:

HDTV Receiver Panel		TV Back
G (green)	=	Y
R (red)	=	Pr
B (blue)	=	Pb

If the receiver has separate sync*, also connect:

H (horizontal sync)	=	H
V (vertical sync)	=	V

* do not connect if HDTV Receiver uses "Sync on Green".

You must also select the DTV Assign Input setting (page 35) of RGB.

4. OPTIONAL: To use TV speaker, connect the L(left) and R(right) audio cables to the optional HDTV receiver and to HDTV AUDIO on the television back panel.

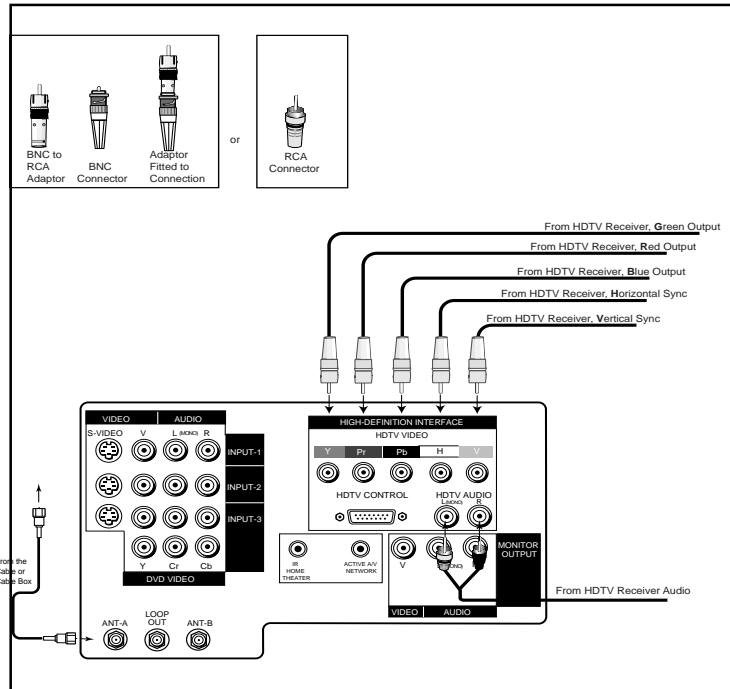

IMPORTANT

1. See Appendix 4 for video signal compatibility information.
2. For Digital Audio connections, see the Owner's Guides of your HDTV receiver and AV receiver.

Remote Control Functions

Select switch

Selects which A/V product will be controlled by the remote

Power

Turns power on and off for the TV or other A/V products

Numbers

Individually select channels or enter information into TV

QV (QuickView™)

Switches to last channel viewed

SQV (SuperQuickView™)

Scan through a memorized list of favorite channels

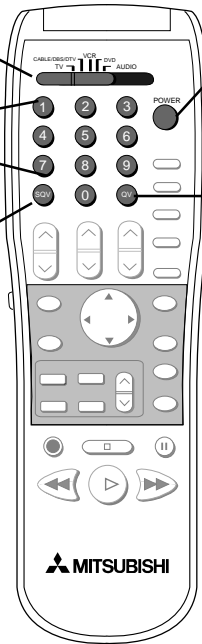

INPUT

Selects the signal you will watch (Ant-A, Ant-B, DTV, Input-1, Input-2, Input-3 [DVD component] and Input-4)

SUB

When optional HD-1080 HDTV receiver is connected, use to enter a subchannel number

SLEEP

Sets the TV to turn off within 2 hours

CHANNEL

View channels in increasing or decreasing numerical order

VIDEO

Individually selects the Video settings

VOLUME

Increases or decreases sound

AUDIO

Individually selects the Audio settings

MUTE

Turns on or off the sound

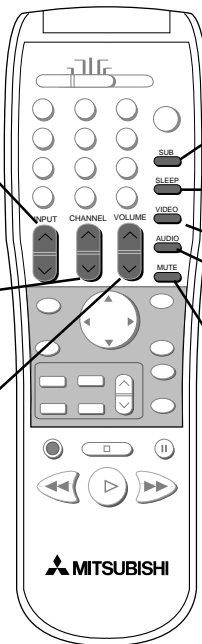

Remote Control Functions, continued

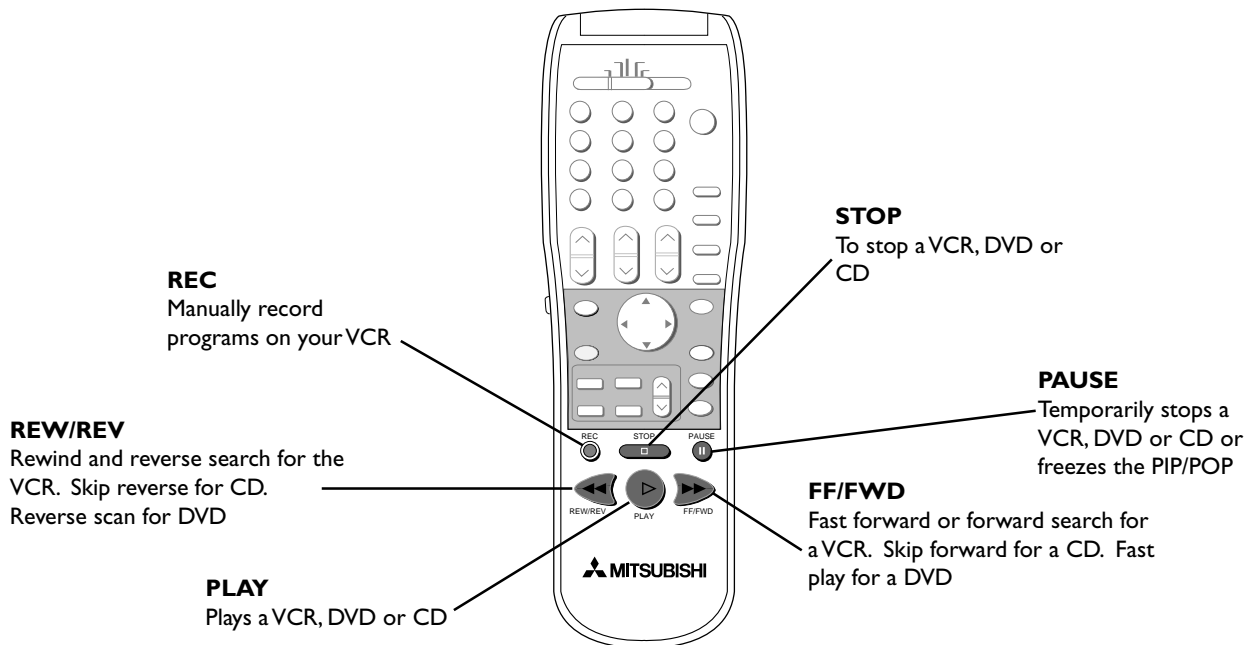
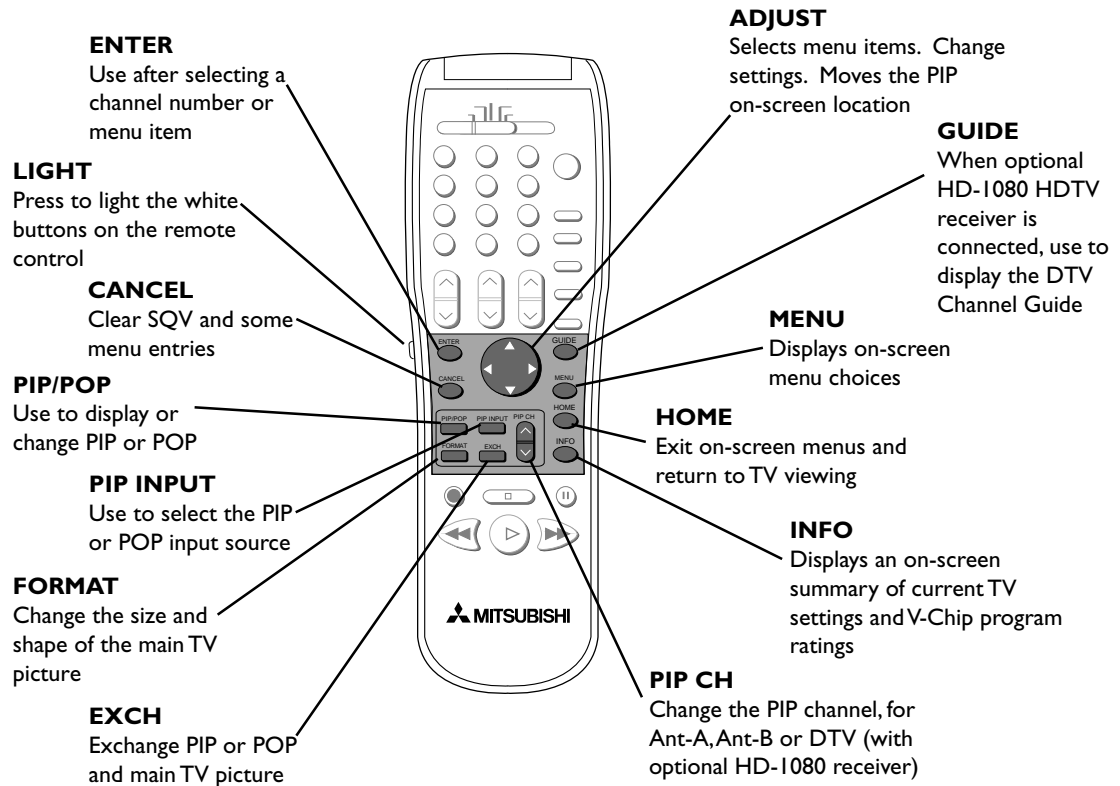

Operating Your Remote Control

Installing the batteries

1. Remove the back cover of the remote control by pushing the tab in the direction of the arrow and sliding off the cover.
2. Load the batteries, making sure the polarities(+) and (-) are correct.

IMPORTANT
When you replace the batteries in your remote control, the remote may return to its initial setting. You may need to set up your remote again.

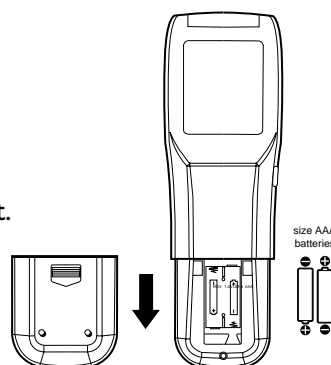

For best results

- Be within 20 feet of the equipment when using the remote control.
- Don't press two or more buttons at the same time, unless you are specifically instructed to do so in this owner's guide.
- Don't allow the remote control to get wet or become heated.
- Avoid dropping the remote control on a hard surface.
- When cleaning the remote control, don't use any harsh chemicals. Use only a soft, slightly moistened cloth.
- Don't mix new batteries with old ones.
- Don't heat, take apart, or throw batteries into a fire.
- Use AAA alkaline batteries.

Using the remote control with your TV

You can use your remote to control the TV, CABLE/DBS/DTV, VCR, DVD or AUDIO. The remote has been preset to operate the TV and other Mitsubishi products. It can be set to control other brands of audio/video equipment.

To operate the TV, the select switch at the top of the remote should be set to TV.

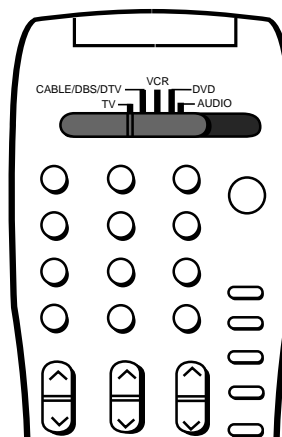

Remote Control of Other Audio and Video Products

Programming the Remote to Control Other Brands of Audio and Video Products:

- Move the slide switch at the top of the remote to select the audio or video product you want to control.
- Press and hold the POWER button, so that it stays down when you enter the code.
- Enter the code for the equipment from the appropriate list, exactly as stated. If there is more than one code number, try the numbers, until you find the correct code.. After setting the code, release the POWER button.
- Point the remote at the equipment and press the POWER button. If it is on and turns off or is off and turns on, the remote will control the equipment. If not, try the next number.

Cable Box codes:

Cable box brand	code to enter:	If your cable box code is not listed here, please see page 79 for a complete listing.
General Instruments/ Jerrold	111, 119, 120, 121, 122, 123, 124, 125, 126, 127	
Oak	102, 137, 139	
Pioneer	101, 116	
Scientific Atlanta	111, 112, 113	
Zenith	100, 117	
To reset to default code, enter 000		

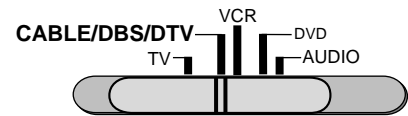

IMPORTANT

If you cannot turn the cable box ON by pressing POWER, try pressing the CHANNEL or the number buttons.

Satellite Receiver codes:

Satellite brand	code to enter:	If your satellite code is not listed here, please see page 79 for a complete listing.
Mitsubishi DTV - DBS	173	
Dishnetwork	175	
Hughes-DSS	173	
RCA-DSS	176	
Sony-DSS	177	
Toshiba-DSS	170	
Panasonic-DSS	174	
Primestar	178	
To reset to default code, enter 000		

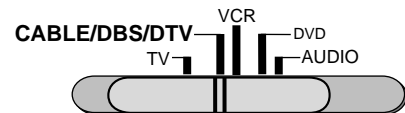

IMPORTANT

When set to TV, the PLAY, STOP, REW/REV and the FF/FWD keys will operate the VCR after the VCR codes have been chosen.

VCR codes:

VCR brand	code to enter:	If your VCR code is not listed here, please see page 80 for a complete listing.
Mitsubishi	001, 002	
Hitachi	020, 043, 065	
JVC	030, 054, 059	
Philips/Magnavox	043, 044, 051	
Panasonic	041, 042, 043	
RCA	020, 053, 065	
Sony	048, 049, 050	
Toshiba	021, 066	
To reset to default code, enter 000		

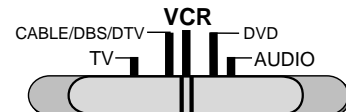

Remote Control of Other Audio and Video Product, continued

DVD Player codes:

DVD/LDP brand	code to enter:	If your DVD code is not listed here, please see page 79 for a complete listing.
Mitsubishi (DVD)	003	
Mitsubishi (LDP)	016, 017	
Panasonic	250	
Pioneer DVD (LDP)	252 (016, 017)	
Sony	254	
Toshiba	253	
To reset to default code, enter 000		

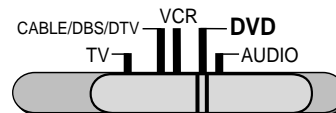

AV Receiver codes:

Audio brand	code to enter:	If your Audio code is not listed here, please see page 79 for a complete listing.
Mitsubishi AV receiver with CD player	010, 011	
Kenwood	200, 208	
Onkyo	209, 214	
Pioneer	205, 207	
Sony	222	
Yamaha	201, 202	
To reset to default code, enter 000		

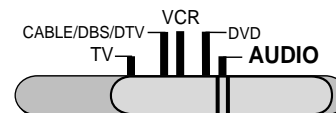

IMPORTANT

If the slide switch is set to TV when you enter an AV receiver code, VOLUME and MUTE will control by the AV receiver, rather than the TV. To return volume and mute control to the TV, set the slide switch to TV, press and hold POWER and enter 000.

Additional slide switch feature: -for multiple A/V component systems

After selecting the correct codes, you can use the slide switch to control more than one type of A/V product. The possible equipment that can be set up for each switch position is shown in the following table. Only one device is allowed for each slide switch position.

TV position: <ul style="list-style-type: none"> • TV • any A/V receiver (volume, mute only) 	Cable/DBS position: <ul style="list-style-type: none"> • cable box or • satellite receiver 	DVD position: <ul style="list-style-type: none"> • any listed DVD or • any listed VCR or • any listed cable box
VCR position: <ul style="list-style-type: none"> • any listed VCR or • Mitsubishi DVD or player 	Audio position: <ul style="list-style-type: none"> • any listed AV receiver or • Mitsubishi CD player or • any listed cable box 	

IMPORTANT

Some manufacturers may change their products, or they may use more than one remote control system. If this is the case, your remote may not be able to operate your VCR, DVD Player, Cable Box, Satellite Receiver or AV Receiver.

Remote Control Channel Selection

There are several ways to select channels with the remote control:

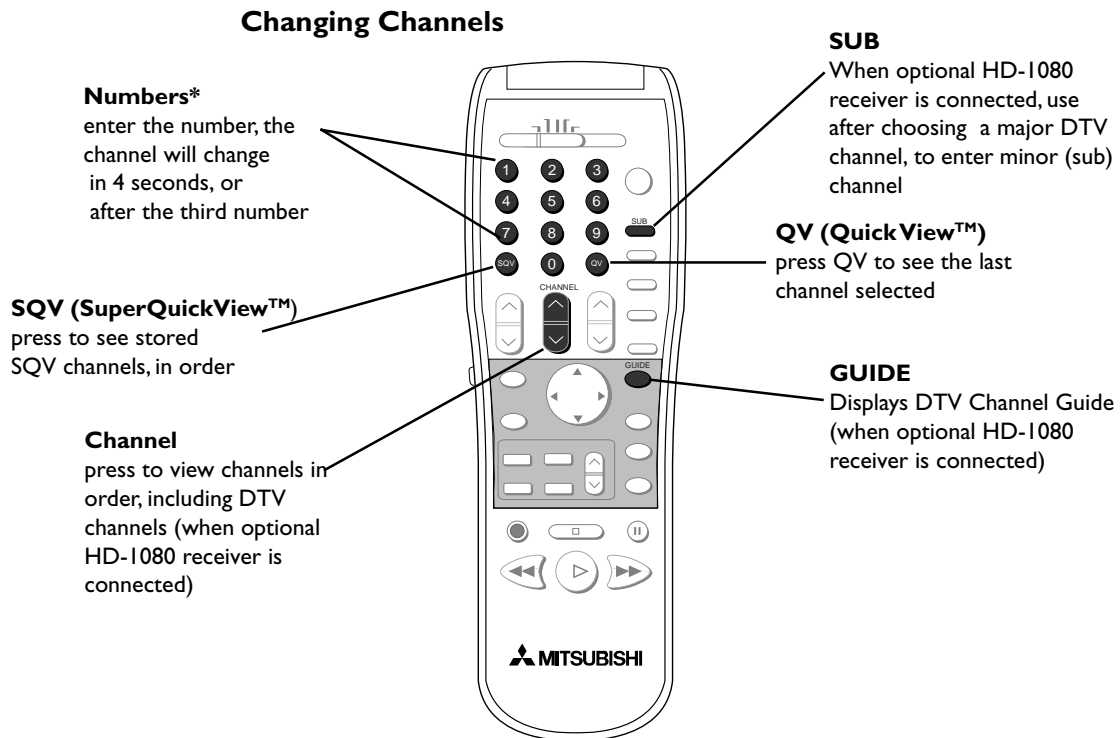

* Using the Number buttons:

For non-DTV channels:

When changing channels directly, you can change them faster by:

1. entering three numbers; for channel 2, press **002**
2. press number and ENTER; for channel 2, press 2 then .

OR

For DTV channels when an optional HD-1080 receiver is connected:

1. Use the number buttons to select the one or two digit major channel.
2. Press .
3. Use the number buttons to select the one or two digit minor channel (if available).

Two asterisks will display if no minor channel exists: 17.**

Two question marks will display while TV is looking for minor channel: 12.??

Remote Control of the Sleep Timer

Setting the Sleep Timer

Press  on the remote control. The TV will display the message:

Sleep: 030 Min.

With each press of  the time increases in 30 minute intervals until the maximum of 120 minutes is displayed.

Release  when the desired time is set.

To see how much time is left until the timer goes off, press  once. The remaining time will display on-screen.

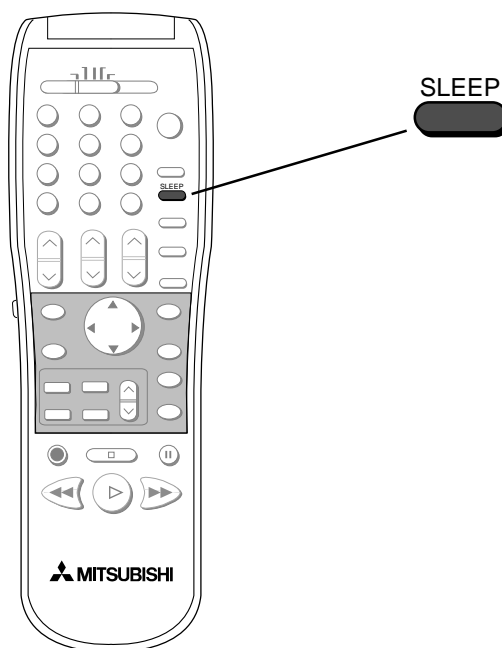

Canceling the Sleep Timer

Press  to see the on-screen display.

Press  until you see the message:

Sleep: OFF

The timer will be canceled.

The ViewPoint® Menu System



Your television has Mitsubishi's exclusive ViewPoint® on screen operating system, which provides on-screen information for menu choices and changes.



A **picture (icon)** will be highlighted when selected with the ADJUST arrows. The picture (icon) indicates that a submenu or automatic function can be changed. Press the **ENTER** button to display the options or start the function.

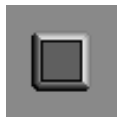

A **square button** indicates that you make changes to this menu choice.

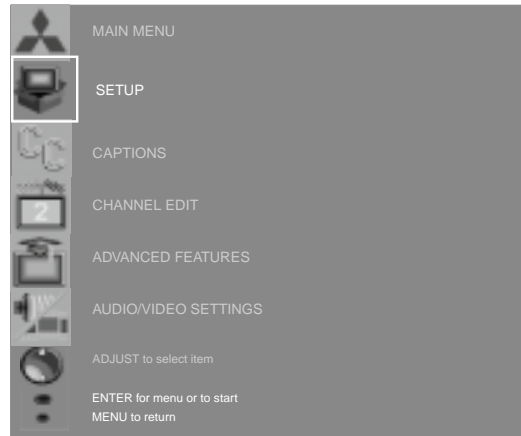

The ViewPoint system includes the following special features:

- The currently selected icon or button is highlighted with a yellow outline and the text color will be yellow.
- On-screen instructions provide complete menu choice information.
- Some on-screen menu options must be set before other options are available. For example, "Set the Timer" will only be possible if "Clock Time" and "Set Day" have been set.

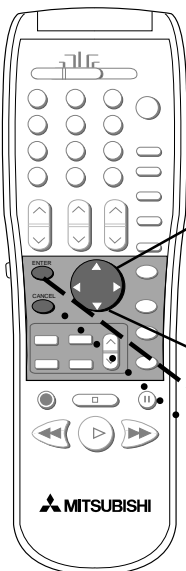

Making Selections:

ADJUST ▲ or ▼ to select the menu item you want to change

ADJUST ► to move to the setting field

ADJUST ▲ or ▼ to change the settings

ADJUST ◀ to move back to the menu item

ENTER ^{ENTER} to select an option, or start an automatic function

CANCEL ^{CANCEL} to clear a setting, or stop an automatic function

To exit the on-screen menus:

MENU Press the MENU key to move back one menu screen at a time until you exit all the menus to return to television viewing

OR

HOME Press HOME to exit all menus with one keystroke and return to television viewing



Menu Screens



The Main Menu Screen will always be the first screen that appears when you press the  button.

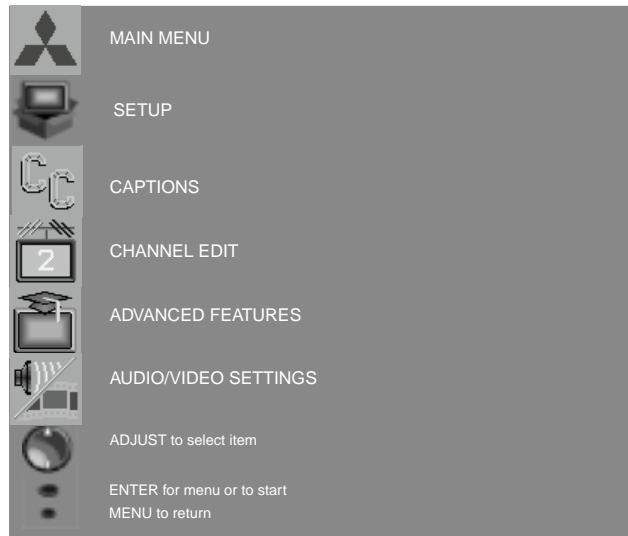

MAIN Menu



Basic set up instructions and procedures are available through the **SETUP** menu screens. You can put channels in memory, set the time and day, set your TV to be part of a Home Theater setup, view the menus in English or Spanish, and turn on or off inputs connected to the television.

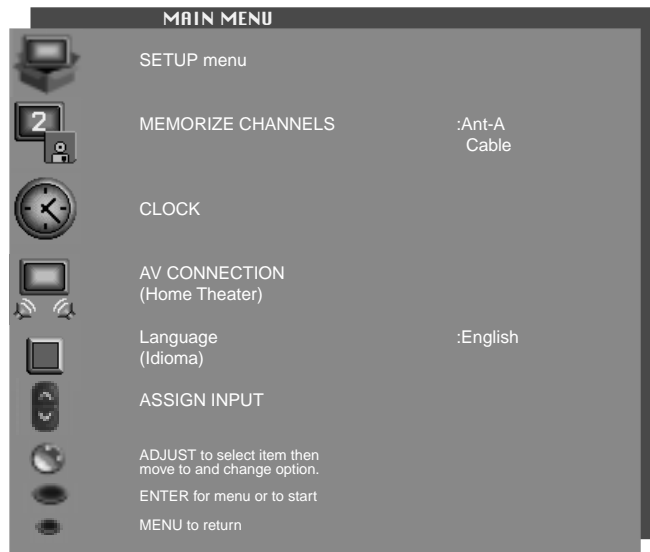

SETUP Menu

Menu Screens, continued



Display captions or text, choose black or gray as the background color for the closed caption area, enable the DTV channel guide (when optional HDTV-1080 receiver

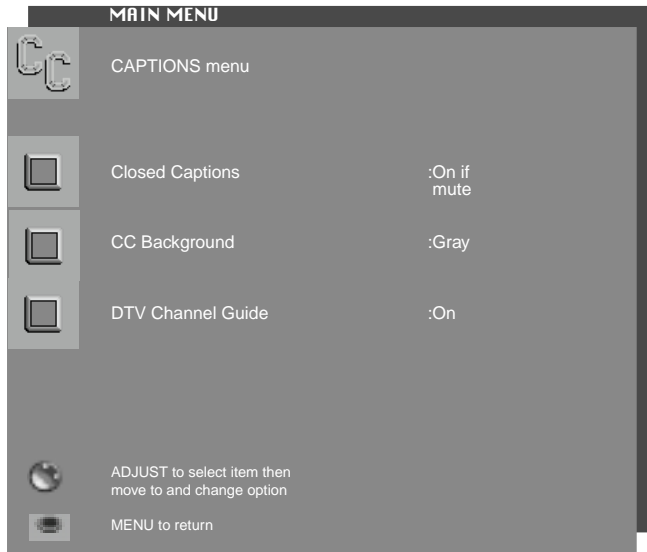

CAPTIONS Menu



Use to customize channel information for Ant-A, Ant-B, and DTV (if optional HD-1080 receiver is connected). Manually add or delete channels from memory, name channels for Ant-A and Ant-B, or add your favorite channels to a SQV (SuperQuickView™) list.



CHANNEL EDIT Menu



Menu Screens, continued



Set your TV to turn on automatically, block unwanted programs with the V-Chip lock, converge (align) the three main colors, change the screen resolution and display a blue screen when showing an input with no signal.

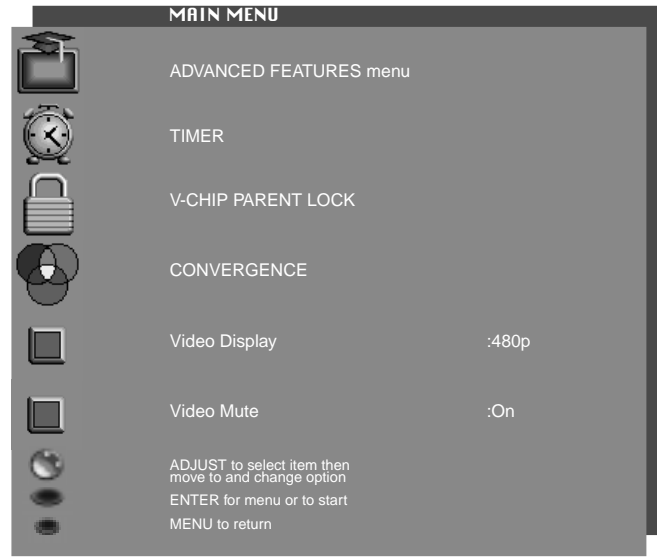

ADVANCED FEATURES Menu



Adjusts some or all of the audio and video settings. Each input can be set to your preferences. AV Reset on the menu allows you to return the audio and video settings for the current input, to the factory presets. AV Reset on the front panel resets all inputs at once. Enhance the brighter parts of dark pictures.

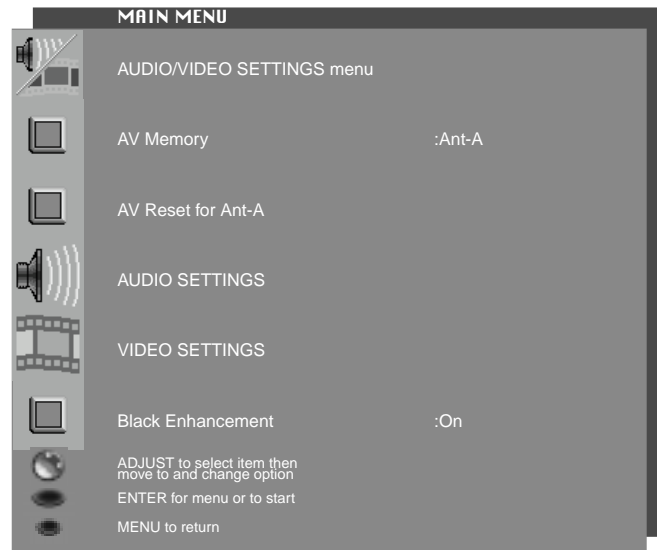

AUDIO/VIDEO SETTINGS Menu

SETUP Menu



Remote control menu selection:

1. to display the Main Menu
2. or and to select the SETUP menu
3. or to select the menu item to change
4. to move to the setting field
5. or to change the setting
6. after making your changes
7. or to select another menu item OR to return to the previous menu OR to return to TV viewing.

This selection memorizes the channels your TV can receive and skips the unused or weak channels.

INPUT	CHANNELS THAT CAN BE MEMORIZED
ANTENNA A AIR	2 through 69
ANTENNA B AIR	2 through 69
ANTENNA A CABLE	1 through 125
ANTENNA B CABLE	1 through 125
HD-1080 DTV	1 through 99

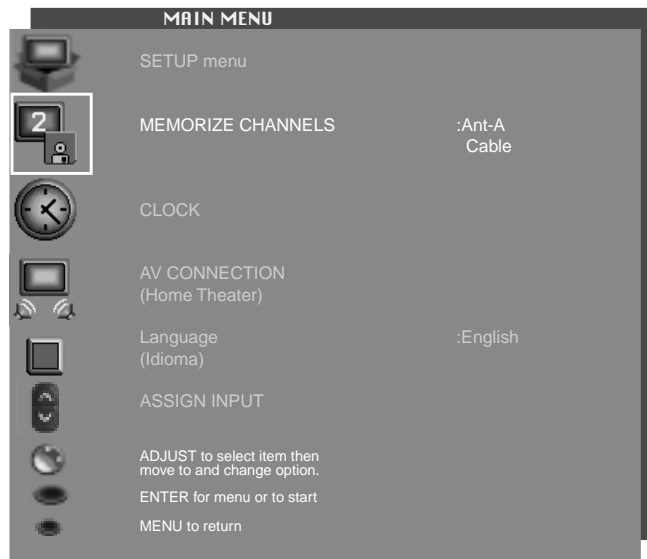

MEMORIZE CHANNELS

IMPORTANT DTV Note

If you have connected a Mitsubishi HD-I080 receiver, you may use this Memorize Channels menu to memorize digital channels. For any other HDTV receiver, you will need to use the channel memorization system in that receiver's menu system.

You can stop the memorization at any time by pressing .

Channels memorized before canceling will stay in memory.

After channels are memorized, your remote control will:

Select memorized channels in ascending or descending order by pressing the channel button.

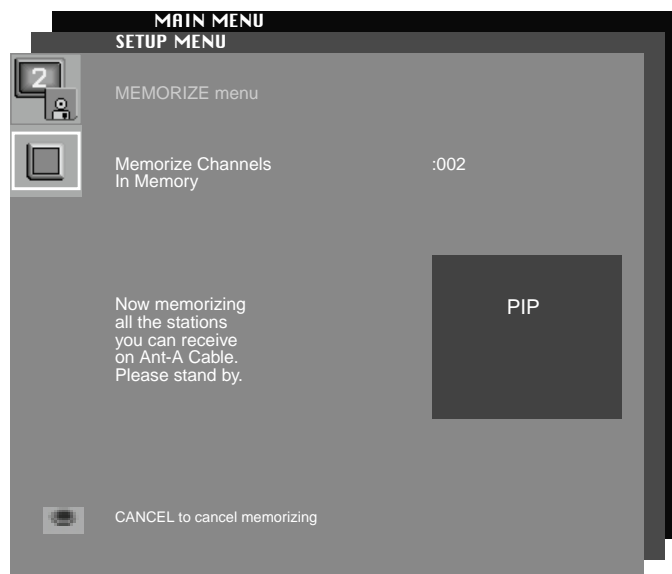

MEMORIZE Menu

PIP will not display in the DTV mode



SETUP Menu, continued

AUTO (automatic) Clock Settings

The clock setting of Auto will automatically set the day and time using Extended Data Service (XDS) time data available when tuned to a PBS or other channel that carries this service.

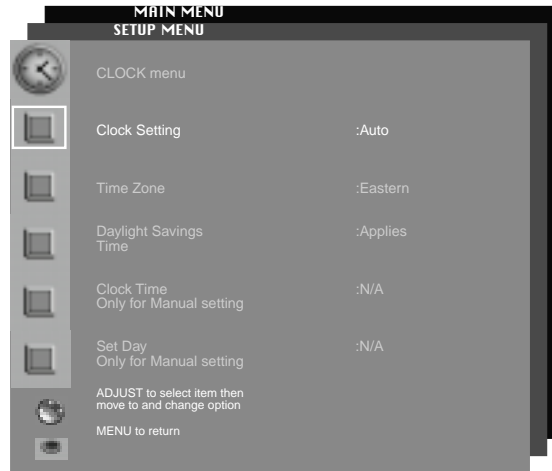

Clock Setting

For the Auto mode you will need to select the correct time zone (Atlantic, Eastern, Central, Mountain, Pacific, Alaska)

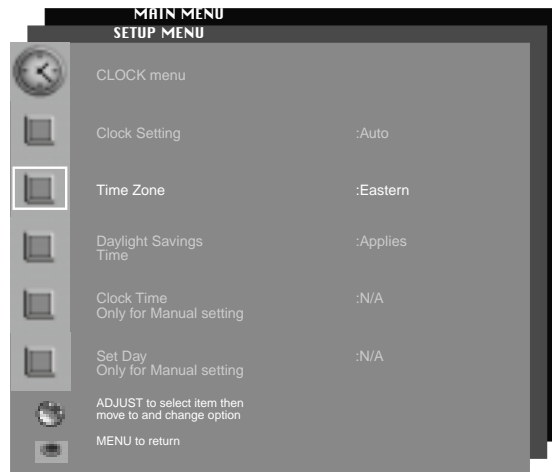

Time Zone

In the auto mode you need to select the Daylight Savings Time (DST) option that your state uses (**Applies:** uses DST or **Ignores:** does not use DST).

The clock time and the day will be automatically set, after tuning to a PBS or other

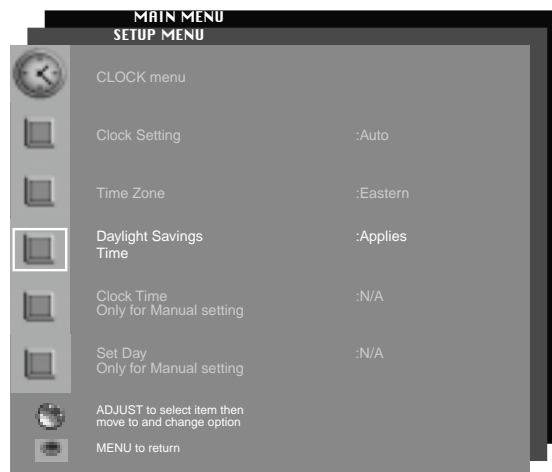

Daylight Savings

SETUP Menu, continued



Remote control menu selection:

1. **MENU** to display the Main Menu
2. **▲** or **▼** and **ENTER** to select the SETUP menu
3. **▲** or **▼** to select the menu item to change
4. **▶** to move to the setting field
5. **▲** or **▼** to change the setting
6. **◀** after making your changes
7. **▲** or **▼** to select another menu item OR **MENU** to return to the previous menu OR **HOME** to return to TV viewing.

Manual Clock Settings

For the Manual clock setting, select the current time, including AM or PM.

Press **▲** or **▼** to slowly adjust the time. Press and **hold ▲** or **▼** to quickly adjust the time.

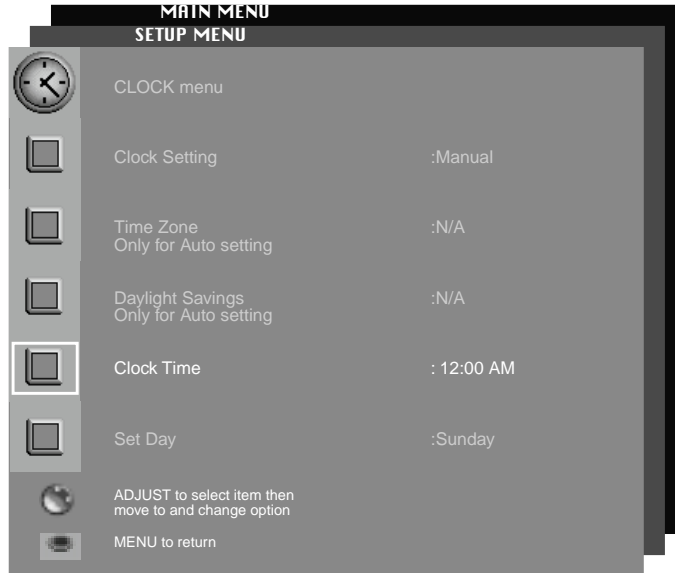

Clock Time

For the manual mode, select the current day of the week.

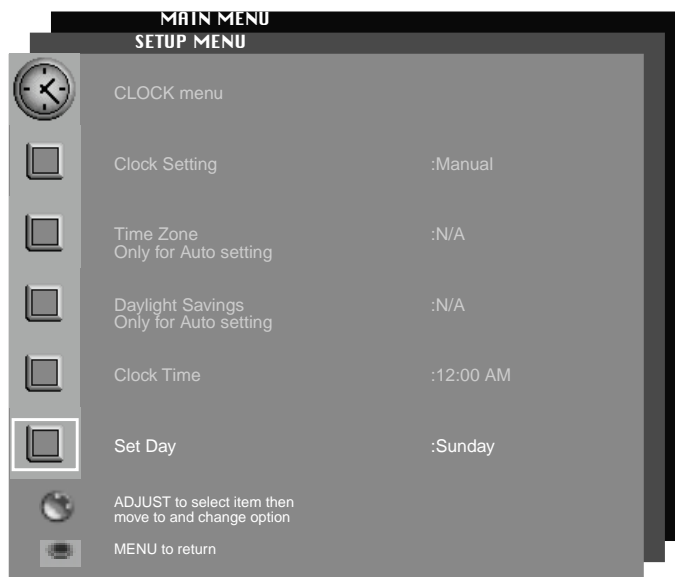

Set Day



SETUP Menu, continued

The AV Connection Menu allows you to customize the way your TV works with other audio and video components, for a complete Home Theater experience. You can adjust:

AV Network

(Active or Off)

TV Speakers

(On or Off),

AV Receiver

(None, Mits A, Mits B, Other)



AV CONNECTION Menu

IMPORTANT

Set the AV Network to Off, if you are not using the AV Network System, for channel selection to work correctly.

Set to Active if you are using a Mitsubishi VCR with Active AV Network connections. This will simplify several common TV/VCR operations to just a few presses of the remote control buttons. If AV Network is set to Off, the AV Network will still transfer Mitsubishi VCR remote control signals to a Mitsubishi VCR that has AV Network connections. This is useful if the VCR is placed inside a cabinet that blocks the direct signal from the remote control. For a detailed explanation of Active AV Network, see page 65.

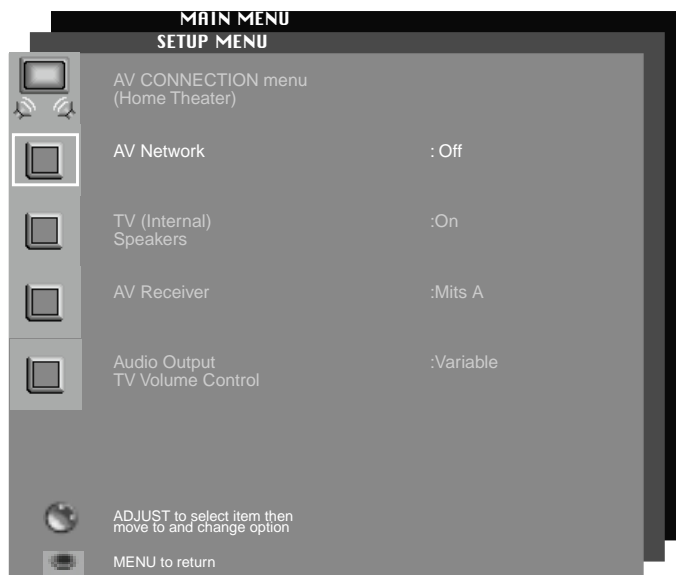

AV Network

Setup Menu, continued



Remote control menu selection:

1. to display the Main Menu
2. or and to select the SETUP menu
3. or to select the menu item to change
4. to move to the setting field
5. or to change the setting
6. after making your changes
7. or to select another menu item OR to return to the previous menu OR to return to TV viewing.

This selection will turn on or off the TV's internal speakers. You may select Off when sending the sound through a separate stereo system or surround sound AV receiver.

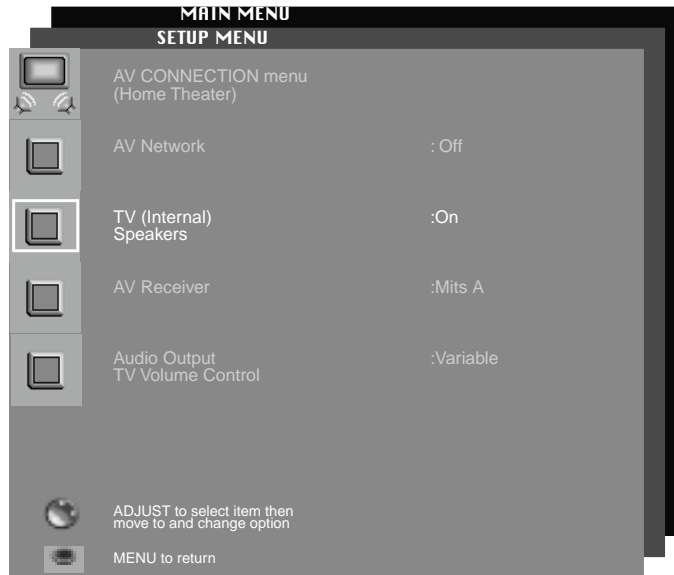

TV Speakers

IMPORTANT

Changing the TV Speakers from OFF to ON will cause the TV speakers to turn on. To prevent damaging the TV speakers from a sudden increase in volume, make sure the TV volume is turned down before choosing ON.

Whether or not you have connected the monitor video output of an AV receiver to the TV's INPUT-1 video input, you will need to set the AV Receiver correctly to one of the following: **Mits-A, Mits-B, Other or None.**

See the next page to determine your correct choice.

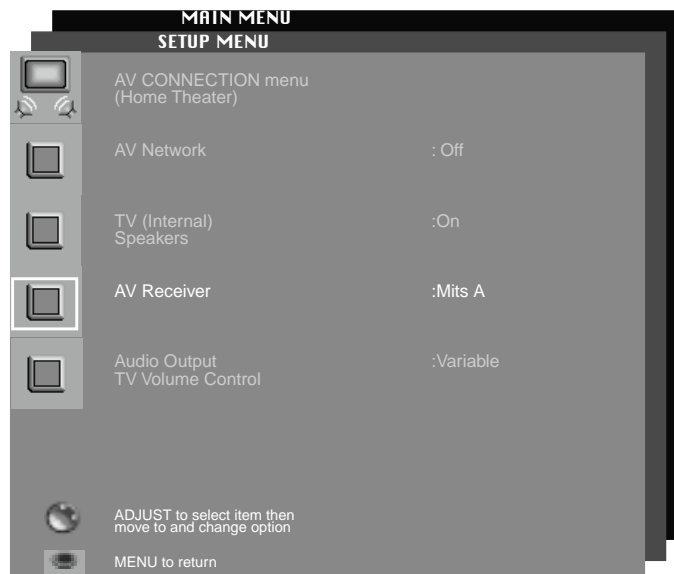

AV Receiver



Setup Menu, continued

AV Receiver choices:

None

When you have not connected an AV receiver monitor video output to the TV INPUT-I video input. The TV will send a video signal to the TV Monitor output.

Mits-A

When you have connected a Mitsubishi digital AV receiver (digital surround sound) model M-VR 800 or M-VR1000. This also activates the Home Theater IR system (see page 67 for correct IR system operation information).

Mits-B

When you have connected a Mitsubishi digital AV receiver (digital surround sound) model M-VR700, M-VR900 or one introduced in 1999 or later. This also activates the Home Theater IR System (see page 67 for correct IR system operation information).

Other

When you have connected any other Mitsubishi AV receiver or another brand of AV receiver. This also blocks signal output from the TV Monitor output when the TV is set to INPUT-I.

Select **Fixed** if your Audio Receiver or Stereo System has a remote control. This allows you to adjust the volume with that remote. Select **Variable** if your Audio Receiver or Stereo System does not have a remote. This allows you to use the TV to

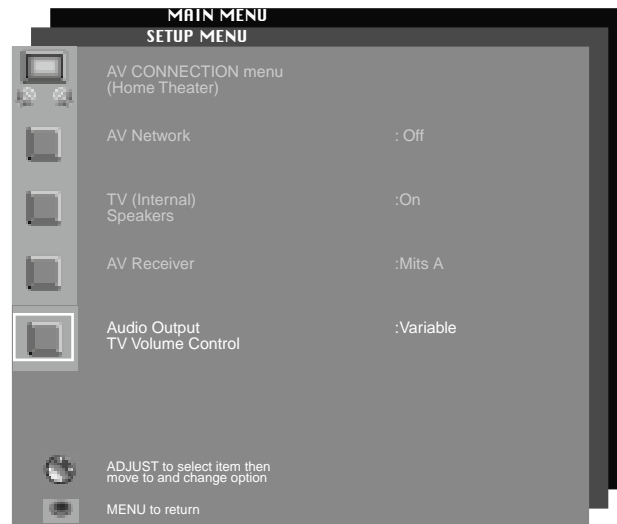

Audio Output

Display the on-screen menus in either English or Spanish (Español). The first time your television was powered on, you were requested to select an on-screen menu language. If the current selection is correct, you do not need to change it.

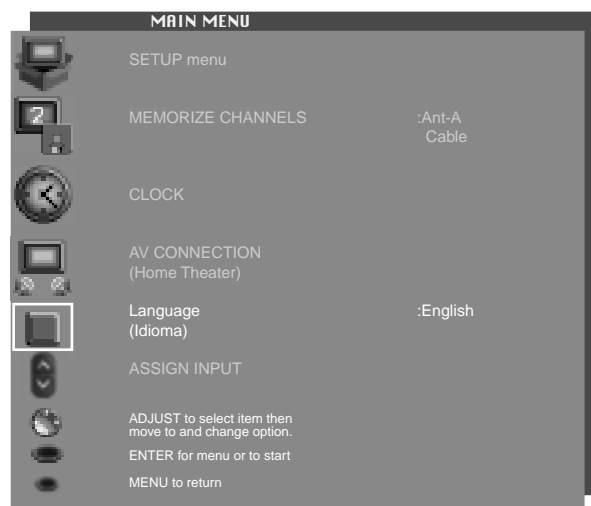

Language

Setup Menu, continued



Remote control menu selection:

1. to display the Main Menu
2. or and to select the SETUP menu
3. or to select the menu item to change
4. to move to the setting field
5. or to change the setting
6. after making your changes
7. or to select another menu item OR to return to the previous menu OR to return to TV viewing.

Assign Input turns off unused inputs, or turns them on again, or changes the name of the input. If you turn off an input, it will be automatically skipped when you press the INPUT button. If you have connected a DVD with component YCrCb output, it will be automatically turned on. Input choices are:

Ant-A, Ant-B

turns on or off antenna inputs used to connect antennas or cable.

DTV

select RGB, YPrPb or OFF, depending on the HDTV receiver connections you made (pages 14 and 15), if any.

INPUT-1, INPUT-2 or INPUT-3

turns off unused inputs or cycles through a list of preset names for audio video product connected to the TV back panel terminals.

Examples of preset names are: VCR1, VCR2, DVD, CAM, etc...

INPUT-4

turns off unused input or cycles through a list of preset names for audio video product connected to the TV front panel terminals.



ASSIGN INPUT menu

CAPTIONS Menu

Broadcasters can send either **standard** or **text** closed captioning.

Standard closed captioning follows the dialogue of the characters on-screen and displays in a small section of the screen.

Text closed captioning often contains information such as weather or news and covers a large portion of the on-screen program.

Your TV can decode four different standard and four different text closed captioning signals from each TV station. However, each station may broadcast only one or two closed captioning signals, or none at all.

Turn on or off the closed caption decoder, choose black or gray as the background color for the closed caption area and enable the DTV channel guide (if optional HD-1080 receiver is connected).

Your DTV receiver or DVD player may not be equipped to display closed captioning.

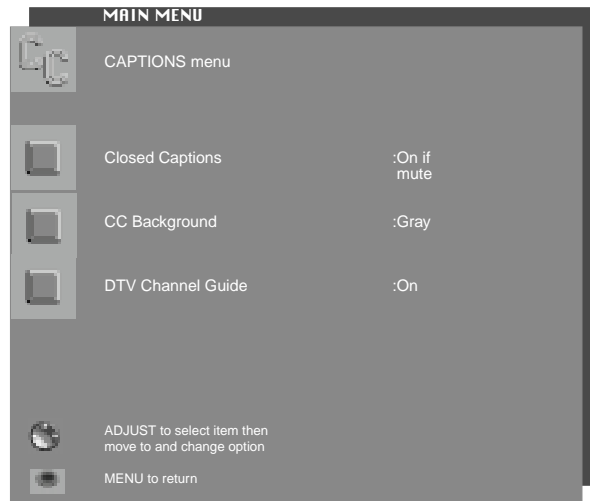

CAPTIONS Menu

IMPORTANT

A large black or gray box will appear on your TV screen, if you have selected text closed captioning, and no text signal is being broadcast.

The TV can display:

CC1, CC2, CC3, CC4
one of four standard closed captioning signals

Text 1, Text 2, Text 3, Text 4
one of four text closed captioning signals

On if mute
closed captions when mute

Off
no closed captions

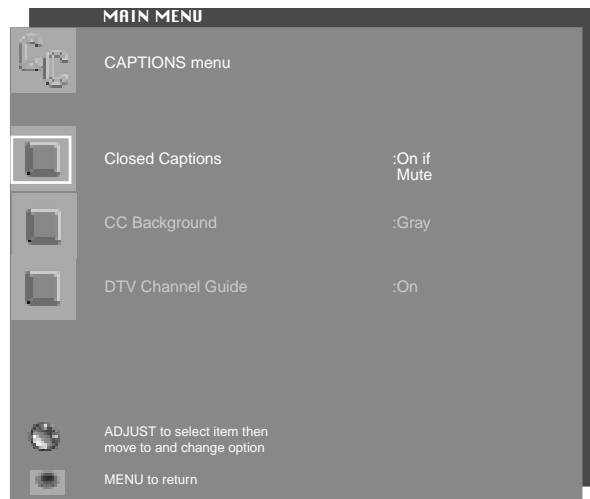

Closed Captions

If you select "On if mute," the standard closed captioning signal (CC1) will appear whenever you use the MUTE button. If you set the decoder to a "standard" closed caption setting or "On if mute" and tune to a broadcaster that is not sending a caption signal, no closed captions will appear.

Captions Menu, continued



Remote control menu selection:

1. to display the Main Menu
2. or and to select CAPTIONS menu
3. or to select the menu item to change
4. to move to the setting field
5. or to change the setting
6. after making your changes
7. or to select another menu item OR to return to the previous menu OR to return to TV viewing.

To make the closed captions easier to read, you can choose to display the background color as either black or gray translucence.

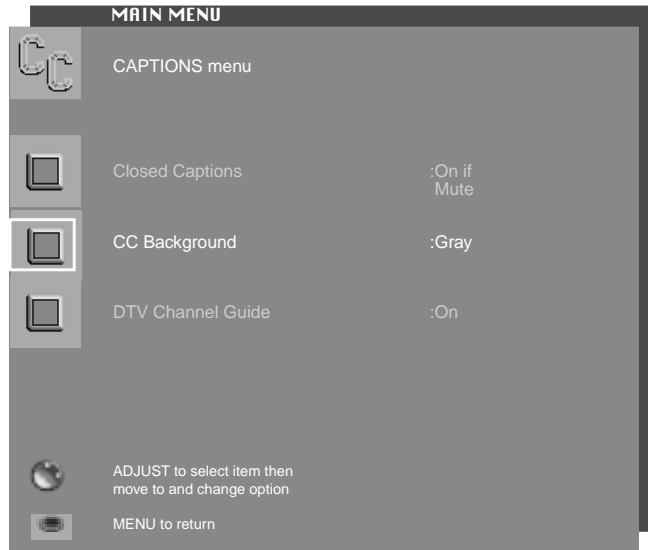

CC Background

IMPORTANT

The content of captions are determined by the broadcaster. If your captions show strange characters, misspellings, or odd grammar, it is not a malfunction of the TV.

If connecting an optional HD-I080 receiver, the DTV Channel Guide can display channel details for the currently selected station.

DTV channels have both major and minor channels capability. A major channel may have several minor channels. Minor channels 01-99 are for broadcast viewing. Channel information and guide availability is determined by the broadcast stations.

Some HDTV broadcasts will only contain major channels and may not contain channel information.

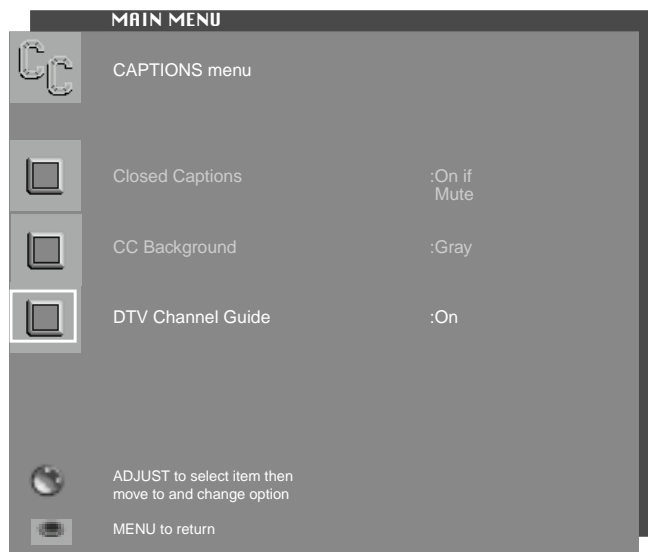

DTV Channel Guide

CHANNEL EDIT Menu



Select Ant-A, Ant-B or DTV (with optional HDTV receiver). For each antenna, you can add or delete channels in memory, name channels and add channels to the SQV (SuperQuickView™) list.

IMPORTANT DTV Note

The DTV antenna will appear as a selection on the Channel Edit menu when the Mitsubishi HD-1080 HDTV receiver is connected. If another HDTV receiver is connected, DTV will not appear as a selection.



Antenna



Channel

Select the channel you want to add or delete from memory, name, or add to the SQV list.

The Channel Edit Menu, continued



Remote control menu selection:

1. **MENU** to display the Main Menu
2. **▲** or **▼** and **ENTER** to select CHANNEL EDIT menu
3. **▲** or **▼** to select the menu item to change
4. **▶** to move to the setting field
5. **▲** or **▼** to change the setting
6. **◀** after making your changes
7. **▲** or **▼** to select another menu item OR **MENU** to return to the previous menu OR **HOME** to return to TV viewing.

After all available channels have been memorized with the “Memorize Channels” feature, weaker channels viewed with Ant-A or Ant-B can be added back in or unwanted channels can be deleted, on an individual basis.

When an optional HD-I080 receiver is connected, you can memorize major channels for DTV input, then add or delete memorized channels.

Use the CHANNEL button on the remote control to view memorized channels.

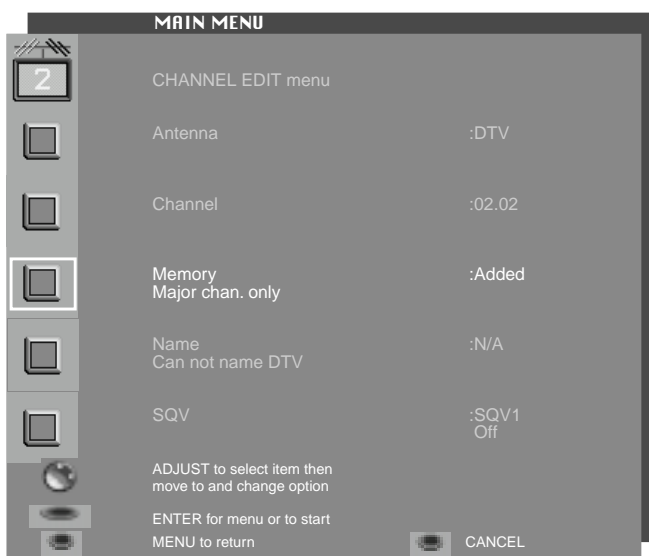

Memory

Channels shown on Ant-A or Ant-B can be given names, up to a maximum of four characters. After you enter a name, it will appear on screen, next to the channel number. Select Ant-A or Ant-B. Select the memorized channel you want to name. At the Name field, you can use letters (A-Z), numbers (0-9) and/or symbols (! . & ' / : * - and blank).

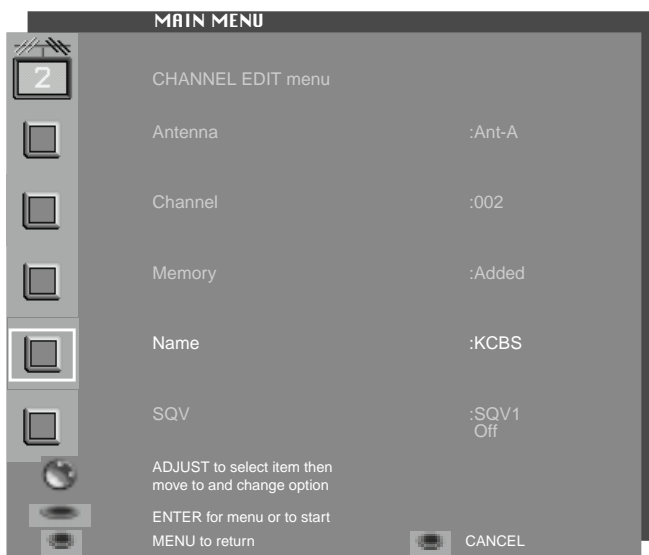

Name

If you want to change your selection while in the option field, use **CANCEL** to delete the current character. You will move one position back. If you press **CANCEL** while at the first character, the entire name will be deleted. Press **▲** or **▼** to change a letter. Press **ENTER** after choosing each letter and after the Name is chosen.



The Channel Edit Menu, continued

SQV (SuperQuickView™) allows you to put together a list of your favorite channels, from Ant-A, Ant-B or DTV (if optional HD-1080 receiver is connected).

You can store up to 6 SQV channels in each of the 9 different memory banks. Once you've added a channel to the SQV memory, the letters "SQV" and the memory bank number appear under the channel number, even if you tune to the channel using another method.

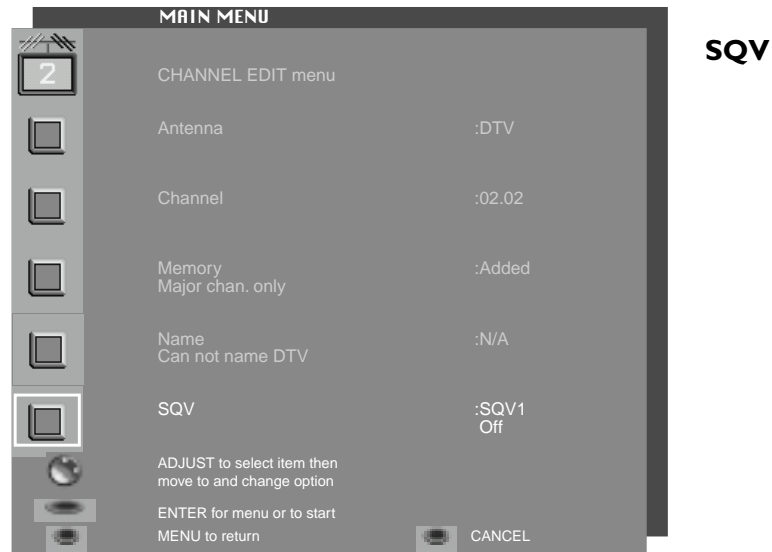

Changing SQV channels and banks using only the remote control

1. Press the SQV button repeatedly to see the desired channel.
2. To change memory banks, press a number button within 5 seconds of pressing the SQV button.

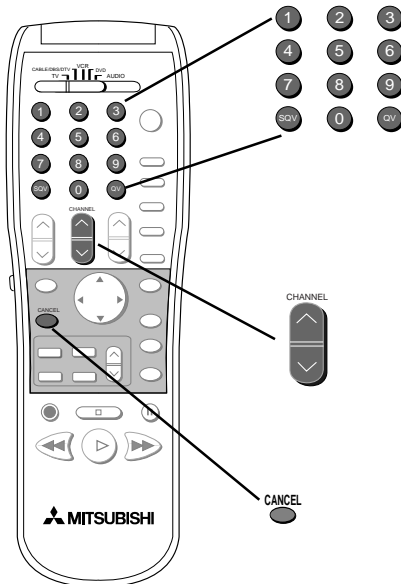

Adding SQV channels using only the remote control

1. Use the CHANNEL or number buttons to select the channel you want to add to the list.
2. Press and hold the SQV button for about 3 seconds. "SQV" and the memory bank number will appear under the channel number, to show that the channel has been added to SQV memory.

Removing SQV channels using only the remote control

1. Press the SQV button repeatedly to select the channel to be removed from the list.
2. While the channel number and SQV indicators are still displayed on the screen, press the CANCEL button.
3. When the SQV indicator disappears, the channel has been canceled from the SuperQuickView list. If you wait until the channel and SQV indicators disappear automatically, then the CANCEL button will not remove the channel from the list.

ADVANCED FEATURES Menu



Remote control menu selection:

1. to display the Main Menu
2. or and to select ADVANCED FEATURES menu
3. or to select the menu item to change
4. to move to the setting field
5. or to change the setting
6. after making your changes
7. or to select another menu item OR to return to the previous menu OR to return to TV viewing.

The timer will automatically, at a specific time, turn the TV on, if it is off. It will tune to a channel on:

Ant-A,
Ant-B,
DTV (if optional HD-1080 receiver is connected)

or select:

INPUT-1, 2, 3 (DVD component) or 4.

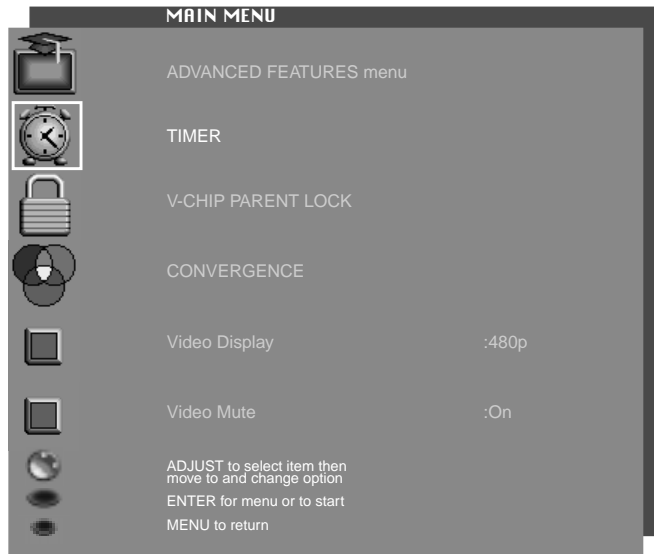

TIMER

IMPORTANT

The TV's clock must be set before you can set the timer. If you haven't set the clock and/or day, you will see the CLOCK Menu instead of the Timer menu.

The timer can be turned On or Off. If you turn On the Timer, you need to select the time to turn on, the day to turn on, the input and the channel to display. Later, if the timer turns the TV on, the message "Press a key for the TV to stay on", is shown. If you don't press a button on the remote control or front panel within 5 minutes, the TV will automatically turn off.

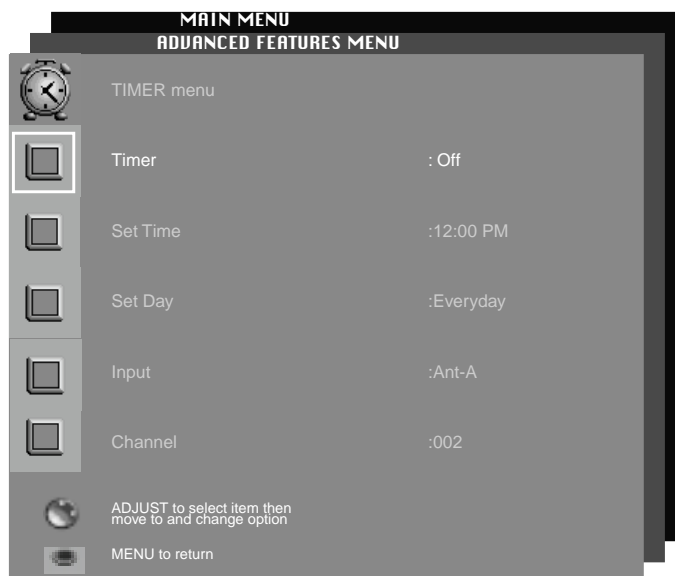

Timer



Advanced Features Menu, continued

Select the hour and minute, including AM or PM, when the television is to turn on.

Press ▲ or ▼ to slowly adjust the time. Press and hold ▲ or ▼ to quickly adjust the time.

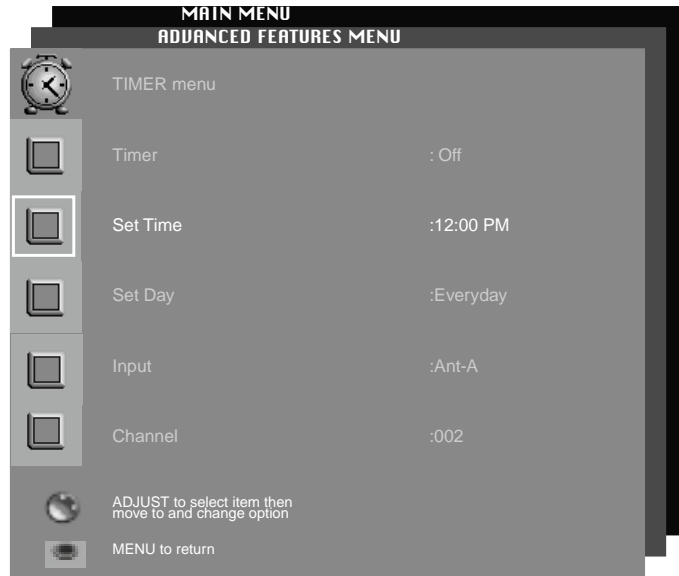

Set Time

Select the days that the television will turn on automatically. You may select Everyday, Mon-Fri (Monday through Friday), or the individual days of the week.

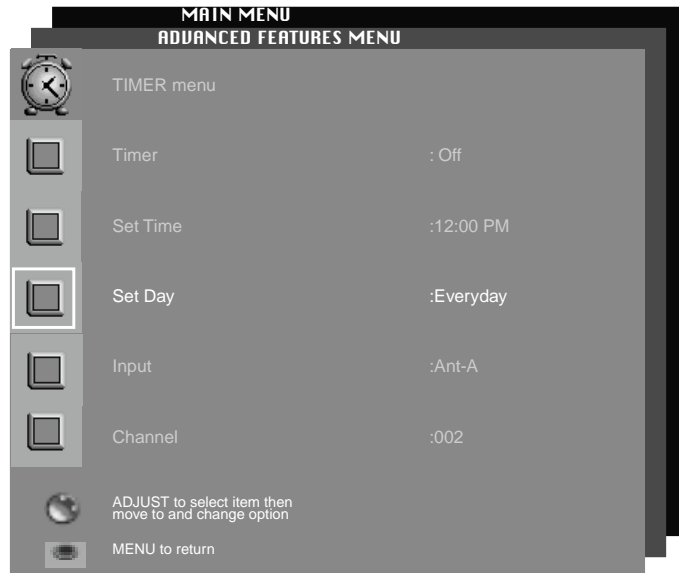

Set Day

Advanced Features Menu, continued



Remote control menu selection:

1. to display the Main Menu
2. or and to select ADVANCED FEATURES menu
3. or to select the menu item to change
4. to move to the setting field
5. or to change the setting
6. after making your changes
7. or to select another menu item OR to return to the previous menu OR to return to TV viewing.

Select the input to use when the timer turns on the TV, or changes the input, if the TV is already on.

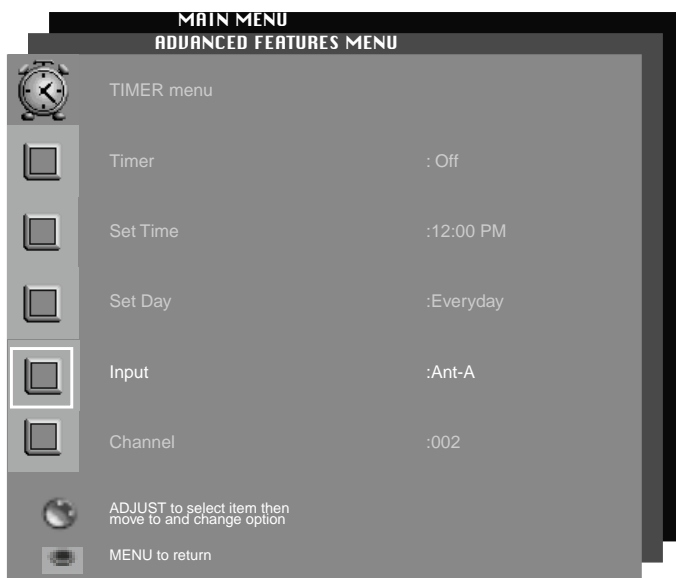

Input

If the selected input is Ant-A, Ant-B or DTV (if optional HD-I080 receiver is connected) channels, you can have the television turn on to any memorized channel.

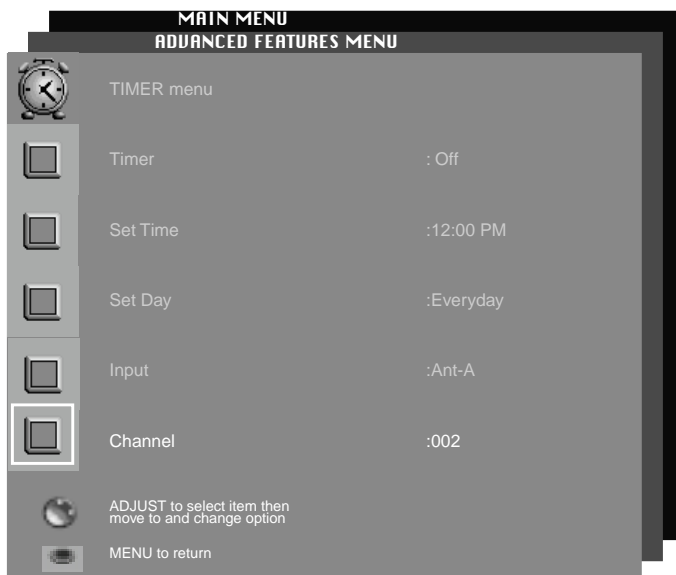

Channel



Advanced Features Menu, continued

The V-Chip Parent Lock allows you to Block or Allow programs based on ratings sent by the broadcast stations. The default setting is to allow all programs. You can block programs by the type of program and by the categories you want blocked. Or you can block all programs during a specific time period.

After changing channels or inputs, there may be up to a 5 second delay, before the V-Chip block takes effect.

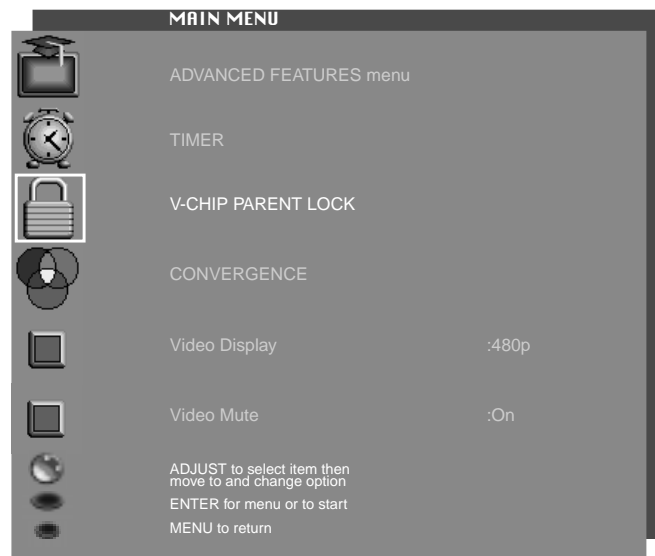

**V-CHIP
PARENT
LOCK**

The first time you select your passcode, or to re-select after permanently canceling it, you will:

Use the number keys on the remote control to choose four numbers for the passcode and then press **ENTER**.

To delete a character and move back one space, press **CANCEL** before pressing **ENTER**.

To exit without entering a passcode, press **MENU** or **HOME** before pressing **ENTER**.

The next time you see a passcode screen, it will display "To go to the menu, enter your passcode...."

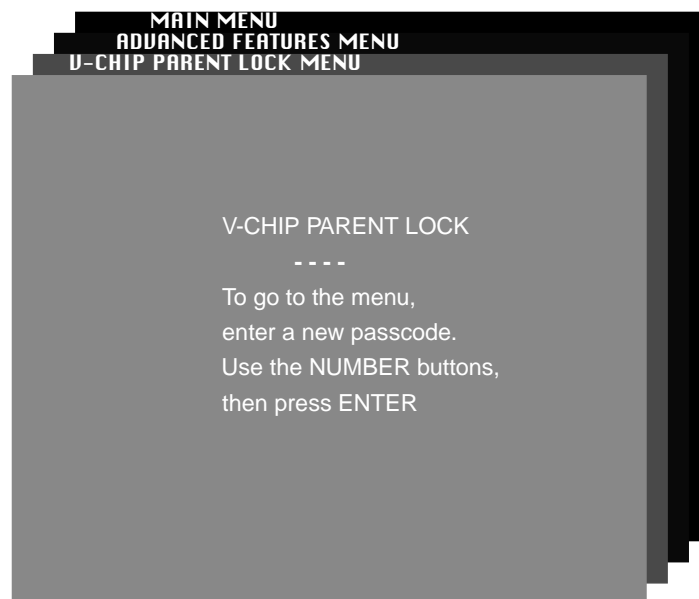

**Entry to
V-Chip
Parent
Lock**

IMPORTANT

If you forget your four-digit passcode, please see Appendix 3 : Procedure for Bypassing the Parent Lock.

Advanced Features Menu, continued



V-Chip rating information is not currently included in all programs sent by broadcasters. This means you may not be able to block the programs. For a more complete blocking system, see the V-CHIP HOURS/LOCK BY TIME section.



V-Chip rating information that may be included with the programs includes:

1. **TV Ratings** - Are age-appropriate as determined by broadcasters.
2. **Lettered categories** - May or may not be sent as part of the V-Chip information provided by broadcasters, along with TV Ratings. Not every lettered category will apply to every TV Rating.
3. **Programs Not Rated** - Some programs may carry V-Chip information of “Not rated”, “N/A” or “None”. These programs may include news, sports, weather, emergency broadcast bulletins or foreign programming.
4. **Movie Ratings** - For movies previously shown in theaters or Direct-to-Video movies. Movie ratings are independent of any TV or Lettered category rating.

Some programs may not carry V-Chip information and cannot be blocked. These may include:

1. Older programs, whether on television, or videotape, disc, etc...
2. HD and 480p programs.

TV Ratings for television programs including made-for-television movies:

- OFF
- TV-Y (youth)
- TV-Y7 (youth, 7 years and up)
- TV-G (general audiences of all ages)
- TV-PG (parental guidance suggested)
- TV-14 (14 years and up)
- TV-MA (mature audience)

Example: If you select TV-PG as the TV Rating then, TV-Y,TV-Y7,TV-G and TV-PG will be allowed.



The V-Chip Parent Lock, continued

Lettered Categories to be used with TV Ratings:

- FV - Fantasy Violence
- D - Sexual Dialog
- L - Adult Language
- S - Sexual Situations
- V - Violence

Age Categories	Lettered categories that may be available for blocking
TV-Y TV-Y7 TV-G TV-P TV-14 TV-MA	FV D, L, S, V D, L, S, V L, S, V

Example: If you block TV-MA **V** then, TV-PG **V** and TV-14 **V** will also be blocked.

Programs Not Rated:

This is an actual broadcast rating for programs that contain V-Chip information of “Not Rated”, “N/A” or “None”.

Example: News, sports, weather, foreign programs and emergency broadcast bulletins.

IMPORTANT

When Programs Not Rated is set to block, emergency programs may be blocked along with other Not Rated programs. Use care when selecting this setting.

For Movies previously shown in theaters or Direct-to-Video:

- Off
- G (general audience)
- PG (parental guidance suggested)
- PG-13 (13 years and up)
- R (restricted)
- NC-17 (18 years and up)
- X (adult)

Example: If you select PG-13 as the Movie Rating then, G, PG and PG -13 will be allowed.

This example shows the settings when the Movie Rating is PG-13, TV Rating is TV-PG and Lettered Categories D and S are blocked.

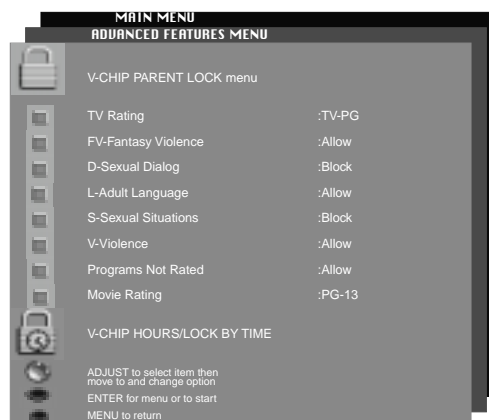

V-Chip Example

The V-Chip Parent Lock, continued



Remote control menu selection:

1. to display the Main Menu
2. or and to select the menu category
3. or to select the menu item to change
4. to move to the setting field
5. or to change the setting
6. after making your changes
7. or to select another menu item OR to return to the previous menu OR to return to TV viewing.

Using the V-CHIP HOURS/ LOCK BY TIME menu, you can activate the V-Chip or lock the entire television, during specific hours by:

1. Blocking some programs during specific hours, using V-Chip Start and Stop Time.

or

2. Blocking all programs during specific hours by selecting the Lock by Time feature with Lock Time and Unlock Time.



V-CHIP HOURS/ LOCK BY TIME

Use the V-CHIP HOURS Start and Stop Times to block programs during specific hours, and later have V-Chip blocking turn off automatically. If the V-Chip start and stop time are the same, the V-Chip will be on 24 hours a day.

Press or to slowly adjust the time. Press and hold or to quickly adjust the time.

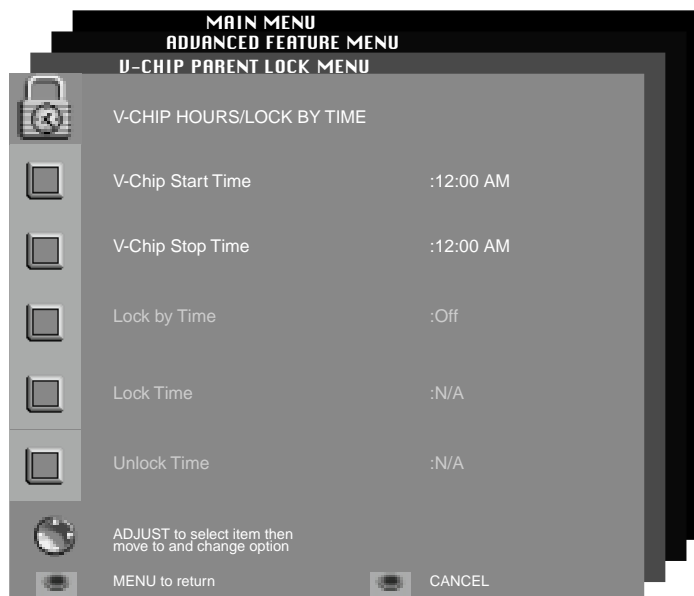

V-Chip Start Time

V-Chip Stop Time



The V-Chip Parent Lock, continued

Lock by Time is an entire TV locking system based on viewing times. When used, the entire TV will be locked between the specified hours. To use the TV during the locked period, you must enter your four digit passcode.

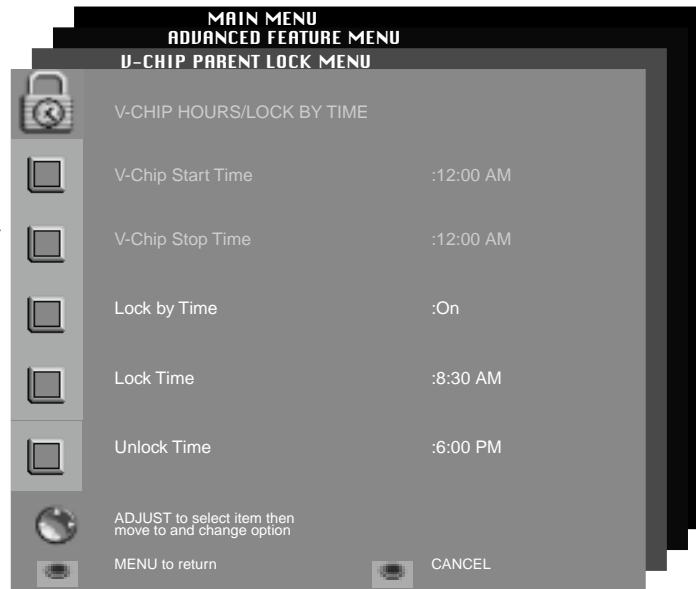

Lock by Time
Lock Time
Unlock Time

To view a blocked program after using the V-Chip block, you will have to enter your passcode to temporarily turn off the block.

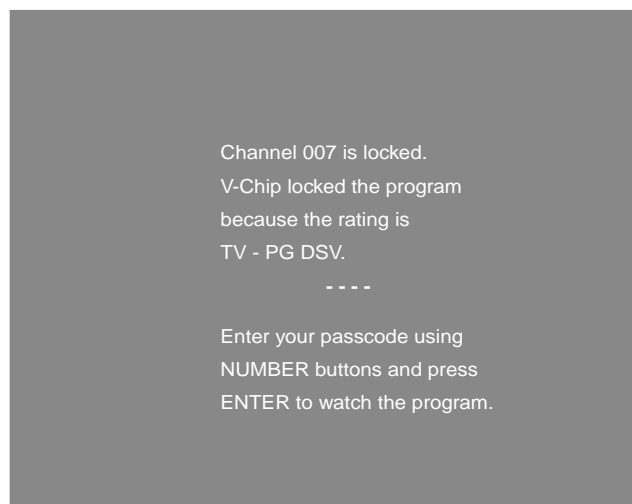

Passcode Screen

IMPORTANT

If Lock Time and Unlock Time are set to the same time, the Parent Lock will be on 24 hours a day.

Advanced Features Menu, continued



Your Mitsubishi Projection TV has three picture tubes with large diameter lenses which are aligned to properly converge the projected light beams on the screen. Each picture tube projects only one color: red, green or blue. During production, your television was carefully adjusted to properly align these colors.

As a special feature, you have the ability to adjust the color convergence, should you think that the red and/or blue light beams are out of alignment. The green beam acts as a fixed reference for aligning the red and blue beams.



CONVERGENCE

Convergence aligns the whole screen at one time. Advanced Convergence aligns 64 individual adjustment positions.

Select either Red Convergence or Blue Convergence to begin alignment.

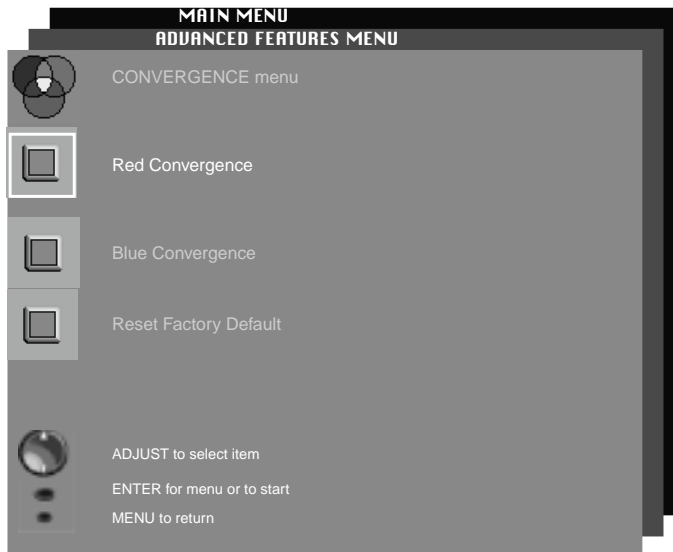

CONVERGENCE Menu

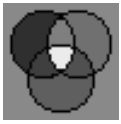

The Advanced Features Menu, continued

When the Red and Blue lines are properly converged, the on-screen crosshairs will be white. You can use ▲, ►, ▼ or ◀ to move the colors toward or away from the crosshairs, until the crosshairs are white.

Press **VIDEO** to switch between RED and BLUE. For Advanced Convergence, press **AUDIO**. Read the on-screen display for further instructions.

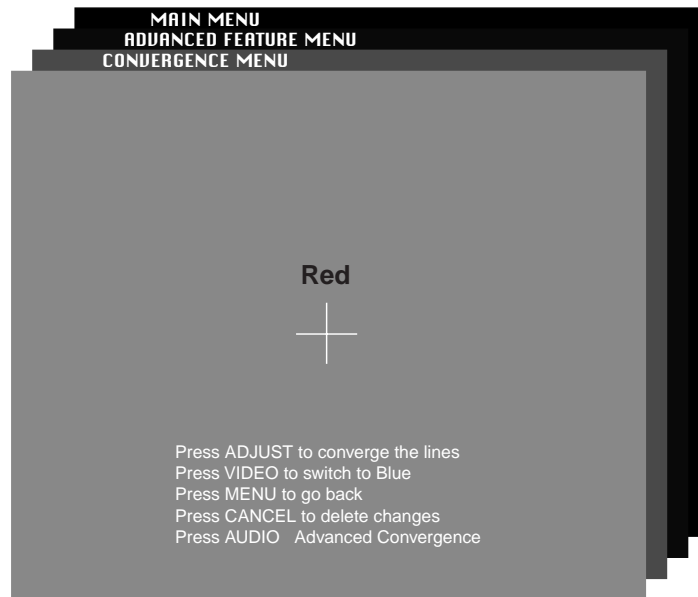

**Red
Convergence**

To restore the convergence factory settings, select Reset Factory Default from the CONVERGENCE menu.

The message “Convergence completed” will display when the factory defaults are restored.

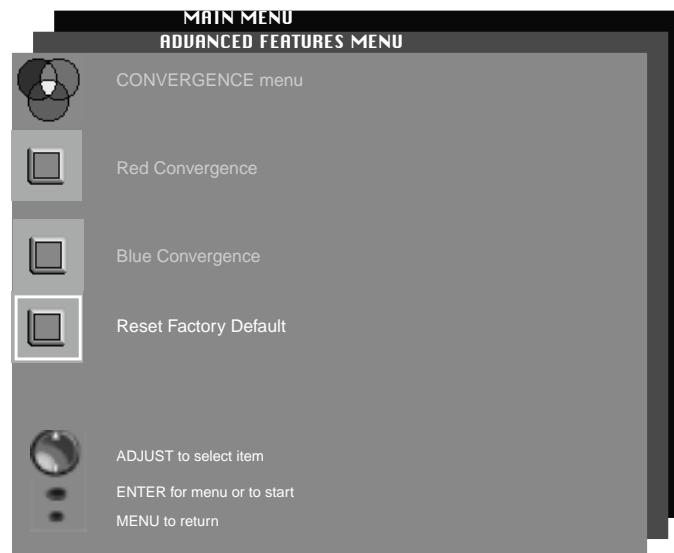

**Reset
Factory
Defaults**

The Advanced Features Menu, continued



Before you can adjust the Advanced Convergence, you must adjust the convergence for both Red and Blue.

Use the ▲, ▶, ▼ or ◀ buttons to move the flashing bracket to a position that needs adjustment.

Press  to stop the flashing. Use the ▲, ▶, ▼ or ◀ buttons to move the red or blue line.

A position is converged when all three lines combine to make a white line.

Press  when aligned, the bracket will start flashing. Use ▲, ▶, ▼ or ◀ to move to a new position.

When finished converging press the  button to save your changes.

Use the  button to switch adjusting between the Red and Blue lines.

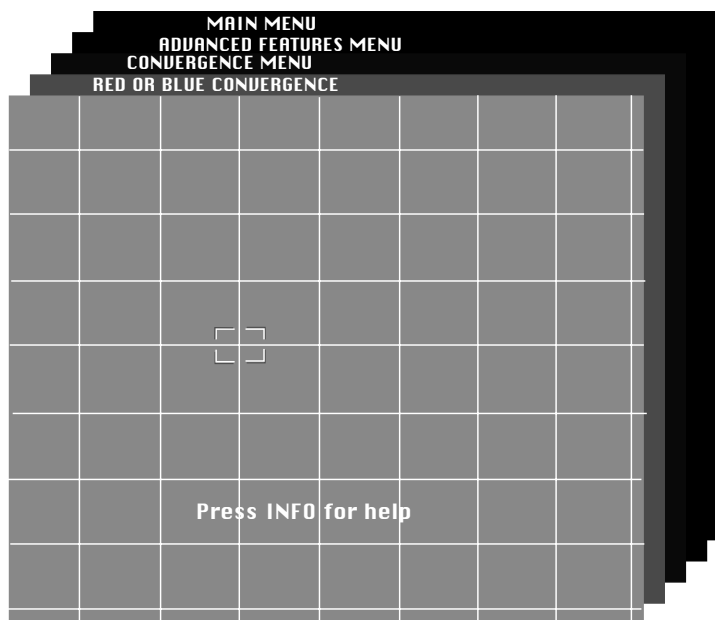

**Advanced
Conver-
gence**

IMPORTANT

There are more than 64 line intersections. However, the bracket will only stop on the 64 adjustment positions.

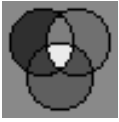

The Advanced Features Menu, continued

Your Mitsubishi television automatically doubles the lines of the standard 480i (interlaced) pictures. This provides a smoother, more film like image.

The default doubling is 480p (progressive). If you prefer, you can choose to display the picture as 960i (interlaced).

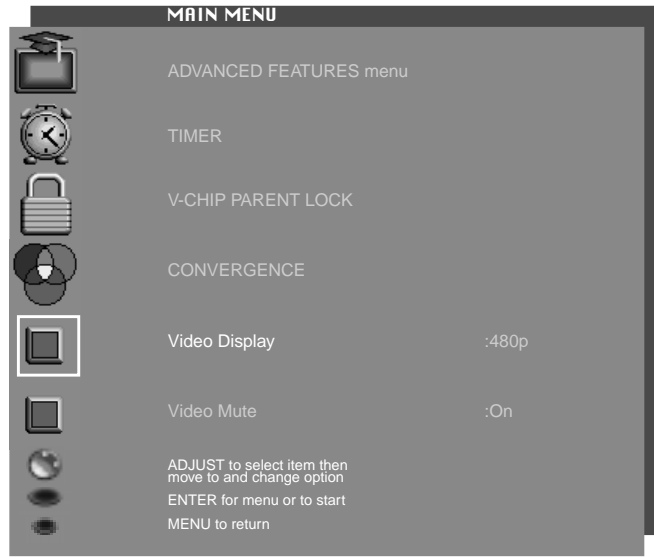

Video Display

Video Mute lets you display a blue or gray screen when no signal is being received, for INPUT-1, 2, 3 or 4.

The V-Chip block will remain off for that channel or input, until the TV power is turned off and turned on again



Video Mute

AUDIO VIDEO SETTINGS Menu



Each of the 7 inputs has its own audio video memory. You can adjust the individual audio or video settings for each input. There are two ways to adjust the settings: by using the remote control buttons with the Menu screen, or with the AUDIO or VIDEO button on the remote control.

After adjusting, every time you select that input, the new settings will be used.

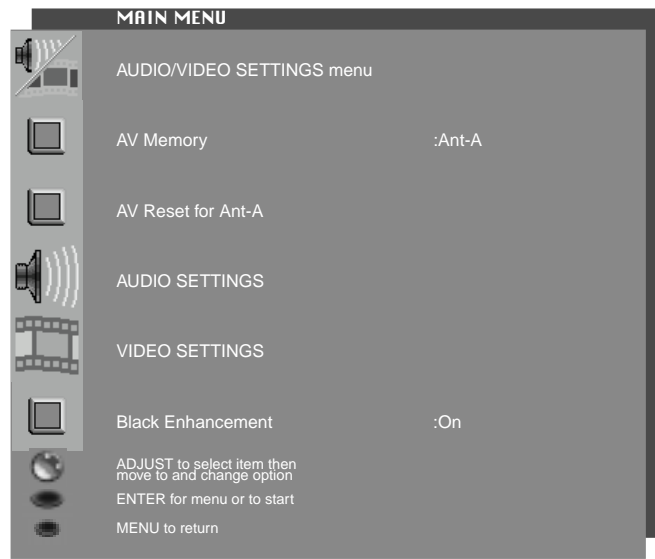

AUDIO/VIDEO SETTINGS Menu

Select the input for the audio and/or video memory settings you want to change.

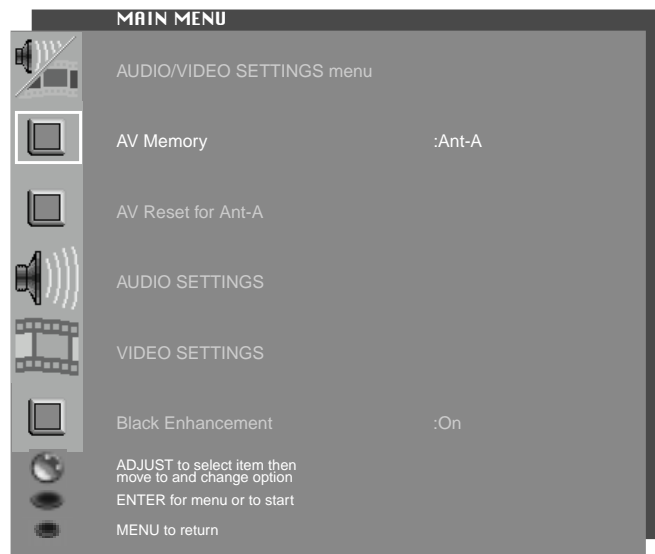

AV Memory



Audio/Video Settings Menu

AV Reset will return the audio and video settings of the currently selected input's memory to the original factory adjustments

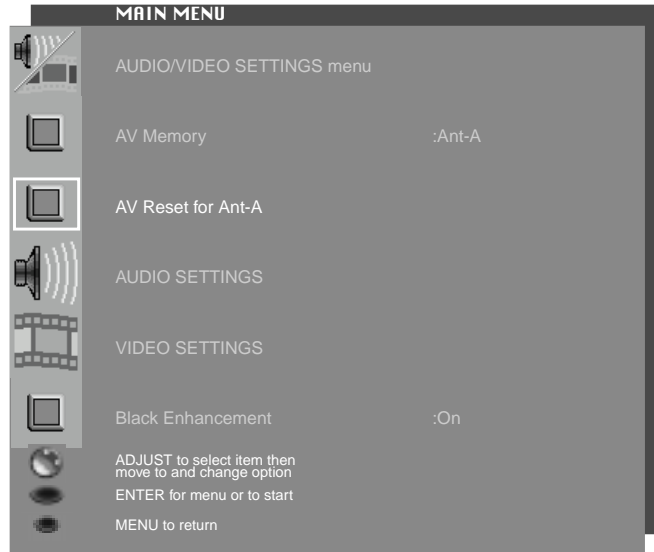

AV Reset

Select either **AUDIO SETTINGS** or **VIDEO SETTINGS**. Then adjust the individual settings with ▲, ▶, ▼ or ◀.

See pages 56-58 for descriptions of the individual audio and video settings.

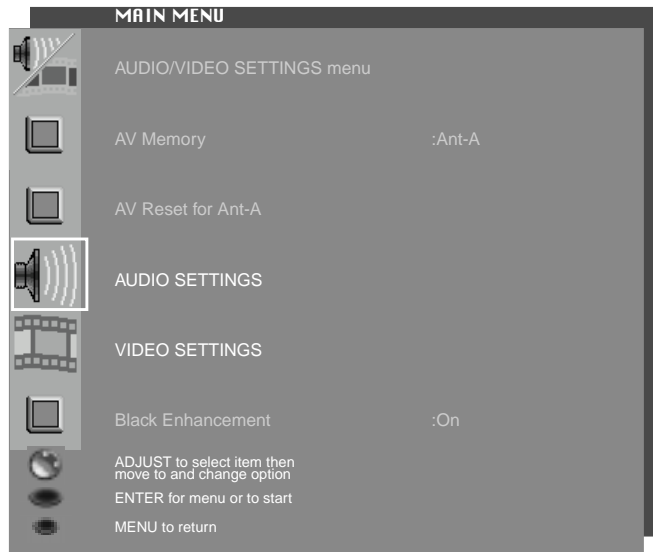

**AUDIO SETTINGS
VIDEO SETTINGS**

Audio/Video Settings Menu, continued

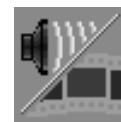

Using the **AUDIO** or **VIDEO** button on the remote control

1. Press **AUDIO** or **VIDEO** repeatedly until the desired setting displays at the bottom of the screen.
2. Press **◀** or **▶** to change the setting. In 5 seconds the display will disappear.

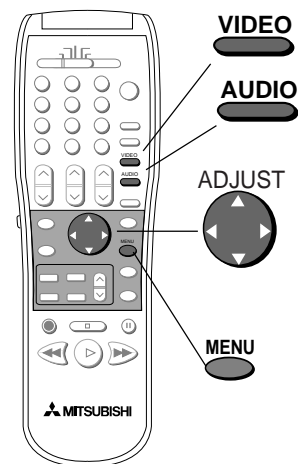

When Black Enhancement is on, dark scenes have the lighter parts of the picture brightened for better viewing. With brighter scenes on the screen, Black Enhancement has little effect.

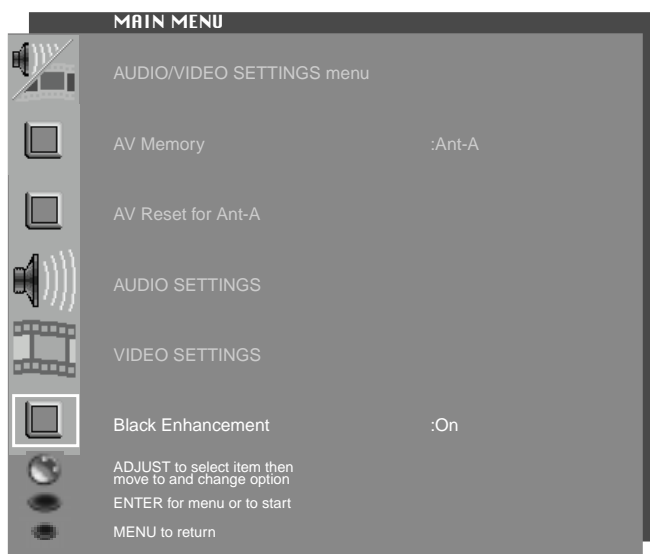

Black Enhancement



Audio/Video Settings Menu, continued

Adjusting the picture

Descriptions of video settings

IRIS™ is the Intelligent Room Illumination (light) Sensor. When IRIS is on, your TV will automatically adjust the picture contrast and brightness for the best picture based on your room lighting. When turned on, Contrast and Brightness cannot be adjusted manually.

Contrast provides a slider that controls the level of white-to-black in the picture. Low contrast will show a variety of shades in the darker images on the screen. High contrast will show the screen's dark images more uniformly black and make the colors on the screen seem more vibrant.

Brightness provides a slider that controls the overall brightness of the picture.

Auto Picture for Ant-A and Ant-B, senses the tuner signal strength. It adjusts picture color and sharpness for the best picture. When turned on, sharpness and color cannot be adjusted manually.

Sharpness provides a slider that adjusts the detail and clarity of the picture.

Color provides a slider that determines the intensity of the color.

Tint provides a slider that adjusts the proportion of red to green in the picture.

Color Temp (Color temperature) allows you to set how the TV will display white images. Your choices are “**Low 6500K** or **Low** (for HD)”, “**High**” or “**Medium.**”

- With the **Low 6500K** or **Low** (for HD) setting, white images on-screen will have a warm cast to them. This adjustment is an average and can vary due to ambient room lighting, video scene brightness and the TV's age. The Low 6500K represents the 6500°K industry standard for NTSC (non-HD) pictures.
- With the **High** setting, white images on-screen will have a cool cast to them. This setting may provide the most realistic picture under bright lighting.
- With the **Medium** setting, white images on-screen will be balanced between the Low (warm) and High (cool) settings.

Video Noise reduces minor video noise (graininess) in the broadcast or input signal.

Audio/Video Settings Menu, continued



Adjusting the sound

Descriptions of audio settings

Bass enhances or reduces low frequency sound.

Treble enhances or reduces high frequency sound

Balance adjusts the level of sound between the left and right speakers.

Surround creates simulated stereo and surround effects. You can set this setting to “**Off**”, “**Simulated Stereo**” or “**Surround Sound**”. Select:

- **Off** when you do not want to use any surround effects. Set the surround setting to “**Off**” when using an A/V receiver with Dolby® Pro Logic Surround, or Dolby Digital Surround.
- **Simulated Stereo** when you are watching a non-stereo program. Your TV will create a simulated stereo effect by using the TV’s speakers.
- **Surround Sound** when you are watching a stereo program. Your TV’s internal speakers will create a simulated surround effect, making the sound seem to extend around and behind you.

Listen to for Ant-A or Ant-B determines how your TV will receive a broadcast audio signal and play back the sound that you hear. You can set this function to “**Stereo**”, “**SAP**” or “**Mono**.”

- **Stereo** is the default setting. With this setting, the TV will play stereo broadcasts in stereo and mono broadcasts in mono. The word “**Stereo**” will be displayed when you tune to a channel broadcasting stereo programming.
- **SAP** is an additional monaural soundtrack that you can’t hear during normal TV viewing. The SAP signal might be related to the program you are watching, such as a soundtrack in a foreign language, or it might be unrelated such as a weather report. If the SAP signal is broadcast, the letters “**SAP**” will appear on-screen when you tune to that channel. Choose “**Listen to: SAP**” to hear the SAP signal.
- **Mono** will reduce background noise and should be used if you are receiving a weak stereo audio signal. The sound will be only in mono even if the program you are watching has stereo audio.



Audio/Video Settings Menu, continued

Adjusting the sound, continued

Listen to for DTV (when using optional HD-I080 receiver) allows you to determine which language your TV will receive a broadcast in, if that language is available for the program. The possible choices are:

- English
- French
- Spanish
- Portuguese
- German
- Italian
- Other

Listen to is not available for INPUTs

PIP Audio Output is available on models WT-46805, WS-55805, WS-55905, WS-65905 and WS-73905. Stereo, SAP, Mono or DTV languages, as available, can be heard through an amplifier or wireless headphones connected to the PIP AUDIO outputs (on the back of the television). This feature allows you to hear sound that is being broadcast through the displayed PIP. Once connected, if the PIP is not displayed you will be able to hear the main TV program through the headphones.

If the PIP input's Audio Output cannot be adjusted, then the letters "N/A" will appear on-screen, when this feature is chosen.

Level Sound automatically equalizes the volume level of programs that contain significant sound level differences from one segment to another, for example: regular programming to commercials. To receive the best audio fidelity for music programs, you may want to turn this setting to Off.

Special Remote Control Functions

When your remote control has been programmed to operate other manufacturer's products the functions it performs on each layer will vary by manufacturer and model. The most common functions are:

VCR:

- POWER
- CHANNEL up/down
- REC
- STOP
- PAUSE
- REW/REV
- PLAY
- FF/FWD

Mitsubishi VCRs will be compatible with additional buttons

Cable Boxes and Satellite Receivers:

- POWER
- CHANNEL up/down
- ENTER (on some models)
- ADJUST up/down/left/right (on some models)
- 0-9 number buttons (on some models)
- CANCEL (on some models)
- GUIDE (on some models)

AV Receivers:

- POWER
- VOLUME
- MUTE

Mitsubishi AV Receivers

- Direct Input Selection buttons (several specific buttons, on some models)

Mitsubishi CD Players when used in combination with Mitsubishi AV Receivers (use audio code 010 or 011):

- PLAY
- FF
- REW
- PAUSE
- STOP

DVD and Laser Disc players (not all functions for all models):

- POWER
- 0-9 number buttons
- MENU
- CANCEL
- STOP
- PAUSE
- REW
- PLAY
- ARROW up/down/left/right
- ENTER

Using PIP and POP Features

PIP (Picture in Picture), Side-by-side and POP (Picture outside Picture) Mode

You can display a large or small PIP (Picture-in-Picture). For widescreen models WT-46805, WS-55805, WS-55905, WS-65905 and WS-73905 you can also display a side-by-side picture, or three or nine POP's (Picture-outside-Picture).

Activating PIP/POP

For models VS-50805 and VS-60805, press PIP/POP once to turn on PIP, a second time for a smaller size PIP and a third time to turn off PIP.

For widescreen models, WT-46805, WS-55805, WS-55905, WS-65905 and WS-73905, press PIP/POP to activate the PIP and POP modes. Each additional press within three seconds will change the PIP to the next mode. Press PIP/POP to see a side-by-side image, again for three POP's, again to see nine POP's, again to see a large PIP and again to see a small PIP. To turn off the PIP or POP, wait more than ten seconds and press PIP/POP.

The next time the PIP/POP is used, the last selected PIP or POP will be the first shown.

PIP INPUT

To see a picture in the PIP inset, you may need to select an input source. If the only input you have connected is ANT A, then both the main picture and the PIP or POP will both be from ANT A.

If you have connected other video equipment, you may be able to view pictures coming from these products in the PIP/POP inset or as the main picture.

Below is a list of main picture and PIP or POP sources that cannot be used together:



- When Ant-A is the main picture, Ant-B cannot be the PIP/POP source.
- When DTV 480p, HD, or DVD 480p is the main picture, PIP/POP is not available from any input or antenna.
- When DTV is the main picture, component video from INPUT-3 cannot be the PIP/POP source.
- When Component video from INPUT-3 is the main picture, DTV cannot be the PIP/POP source.
- For widescreen models in the side-by-side mode, the same picture cannot be shown in the main picture and side-by-side.

To see if DTV 480p, HD or DVD 480p is the main picture, press the INFO button. The on-screen display will list 480P or HD 16:9 when those signals are received.

Using PIP and POP Features, continued

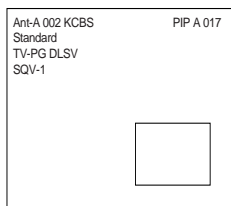

Using the PIP INPUT button



1. To view a PIP image, press .
2. To see the available PIP inputs, press  repeatedly. The input name will be displayed on screen for about five seconds. The equipment connected to INPUT-1, 2, 3 (DVD component), 4 or DTV needs to be turned on to show a PIP or POP.

Using the PIP CH button

When a PIP or POP channel is displayed, the PIP CH button can change PIP or POP channels for Ant-A, Ant-B or DTV (when optional HD-1080 receiver is connected).

1. Press .
2. Press  to show a different channel on the PIP or POP.

Using the ADJUST button with PIP or POP

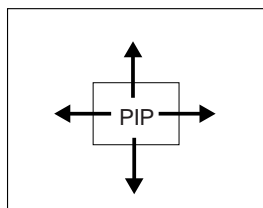

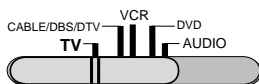

PIP:
Press  to move the PIP image anywhere on the screen.

POP:
Press  to change to a different "live" POP image.



Using the PAUSE button with PIP, Side-by-Side or POP (select switch must be in TV position)

PIP:
While viewing a PIP or side-by-side channel, press  to freeze the image. Press  again to return to a live picture.

To bring a frozen PIP image on-screen, press .

POP:
Press  to keep the same active POP and stop automatic switching.

Press  again to return to automatic POP switching.

Using PIP and POP Features, continued

Using the EXCH button with PIP

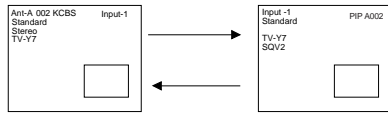



EXCH
Press  to exchange the PIP and main picture image.

Using the PIP/POP button to display Side-by-Side or POP'S (Picture-Outside-Picture's) for models WT-46805, WS-55805, WS-55905, WS-65905, WS-73905

Your choices are to view:

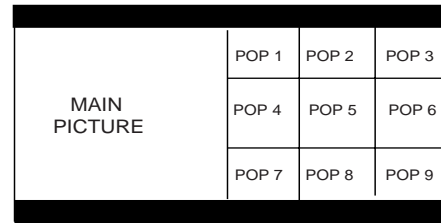
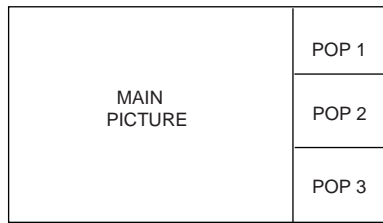
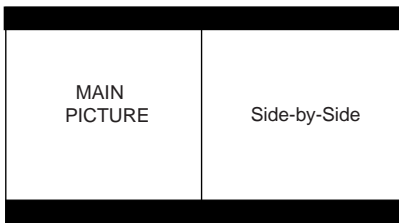
- Side-by-Side
- Three POP's
- Nine POP's
- PIP, large or small



To display the PIP or POP you want, press ^{PIP/POP} until the desired PIP or POP sequence is displayed.

When displaying three or nine POP's, only one image will be a moving picture. The others will be still.

Press ^{FORMAT} to remove the black bars.

Using PIP Audio for models WT-46805, WS-55805, WS-55905, WS-65905, WS-73905

To hear PIP or POP sound when viewing a PIP or POP picture, you need to connect an amplifier, or wireless headphones to the PIP AUDIO OUTPUT terminal on the back of the television. If no PIP or POP picture is displayed, the sound will be the same as the main TV picture. Volume for PIP AUDIO OUTPUT is controlled by the amplifier or wireless headphones.

Warning: Don't display the same stationary images on the screen for more than 15% of your total TV viewing in one week. Examples of stationary images are letterbox top/bottom bars from DVD disc or other video sources, side bars when showing standard TV pictures on widescreen TV's, stock market reports, video game patterns, station logos, web sites or stationary computer images. Such patterns can unevenly age the picture tubes causing permanent damage to the TV. Please see page 74 for a detailed explanation.

Formats

Widescreen models **WT-46805, WS-55805, WS-55905, WS-65905** and **WS-73905**

Pressing the FORMAT button will cycle through the three different picture shapes or formats that can be used with traditional TV broadcasts, videotapes, laser discs, some DVDs and some DTV broadcasts. The three formats are:

- **Standard** - The picture is the traditional TV shape in the center of the screen with gray sidebars. If this is a letterbox picture, there will be black bars at the top and bottom.
- **Expand** - The picture is stretched left-to-right to fill the screen with no loss of picture resolution. Letterbox pictures will still have black bars at the top and bottom.
- **Zoom** - After expanding the picture left-to-right, Zoom will stretch the picture top-to-bottom, and there may be some loss of picture at the top and bottom. This format will reduce or remove the black bars from letterbox pictures.

All HD signals (1080i) and DTV 480p or DVD 480p signals will automatically fill the screen from top-to-bottom and left-to-right and the FORMAT button will be disabled.

The FORMAT button can be used during POP functions if closed captions are turned off.

Anamorphic Pictures

Some DVD discs might have anamorphic pictures. Anamorphic pictures are specially designed for display on widescreen TVs (the DVD player should be set to “TV Shape 16:9”). We recommend using the Expand format with these programs to enjoy the benefits of full screen display, proper image shape and high resolution. Some anamorphic pictures are in special movie theater widescreen shapes and might be marked “aspect ratio 2.35:1”. These images will still show small black bars at the top and bottom of the screen when displayed in the Expand format.

Standard shape models **VS-50805** and **VS-60805**

These models have two different shapes or formats for use with traditional TV broadcasts, videotapes, laser discs, standard DVD players (not DVD 480p). The formats are:

- **Standard** - The picture fills the screen. Letterbox pictures will have black bars at the top and bottom.
- **Wide** - The picture is compressed from top-to-bottom and black bars are added at the top and bottom. This format is recommended only for anamorphic DVDs. This will allow full picture resolution and correct the picture shape. It is important that the DVD player be set to “TV Shape 16:9”, otherwise the picture will appear stretched.

When the closed caption decoder is turned off, the Wide format is available.

All HD signals (1080i) will automatically be displayed in the Wide format and the FORMAT button will be disabled.

DTV 480p or DVD 480p signals will always fill the screen from top to bottom and the FORMAT button will be disabled. Make sure your HDTV receiver and DVD player (if using the 480p component outputs of the DVD player) are set to “TV shape 4:3”.

Format examples:

Widescreen models WT-46805, WS-55805, WS-55905, WS-65906 and WS-73905

Standard Picture

Letterbox, non-anamorphic

Anamorphic widescreen

Standard format

Standard format

Standard format



Press  for Expand format

Press  for Expand format

Press  for Expand format



Press  for Zoom format

Press  for Zoom format

Press  for Zoom format

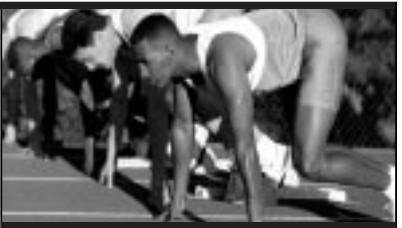

Standard models VS-50805 and VS-60805

Standard format

Standard format

Standard format



Wide format

Wide format

Wide format



Remote Control of the Active AV Network

The AV Network is a special feature that makes it easier to use your television and Mitsubishi VCR together. When the AV Network is connected, you can point the remote control at the television, and it will pass the remote control command to your Mitsubishi VCR. You will gain even more benefits if you have a Mitsubishi VCR equipped for the Active AV Network and a Mitsubishi DVD player.

Before you begin, be sure you have:

- Made the correct AV Network connections. Refer to “*Connection of TV to the Active AV Network*” in the Connections section.
- Connected your VCR to INPUT-I of your TV and/or connected your DVD to DVD INPUT.
- Set your VCR’s remote control settings to VCR or VCR A (if your VCR has an A and B setting).
- Turned your VCR video mute setting on.
- Turned the Active AV Network feature in both the VCR and the TV’s menu to ACTIVE.

Using the **PLAY** key on the TV remote, after selecting VCR with the slide switch:

- Active AV Network will turn your VCR on and begin playing a tape (if tape is inside).
- Active AV Network will turn your TV on and switch it to INPUT-I.
- When you turn your TV off, your VCR will turn off, **unless** it is playing or recording.

Displaying the VCR menu, after selecting VCR with the slide switch:

When you set the remote to VCR and then press MENU:

- Active AV Network will turn on your VCR if it is off and display the VCR’s menu (this function may not work with some older Mitsubishi VCR’s).
- Active AV Network will turn on your TV if it is off and switch it to INPUT-I.

Using the **PLAY** key on the remote, after selecting DVD with the slide switch:

- Your remote must be programmed to operate Mitsubishi DVD players.
- Active AV Network will turn on your TV and switch it to DVD INPUT-3.
- If your DVD player is in range of the remote and has a disc inside, the DVD will turn on and the disc will begin playing.

IMPORTANT

1. **When using the Active A/V Network, always point your remote control at your television.**
2. **If you are using the Active A/V Network with the Home Theater IR system control on page 66, make sure both the TV and AV receiver are powered on before pressing the Play button on the VCR or DVD.**

Mitsubishi Home Theater IR System Control using Infrared Emitter

The Mitsubishi Home Theater IR System Control is a special feature that makes it easier to use your television with a Mitsubishi digital AV receiver. Once your equipment is properly connected and set up, your TV and Mitsubishi digital AV receiver will change inputs together, to match high resolution pictures with the proper surround sound.

When you change inputs on your TV to watch different video products, your TV will send signals via the infrared emitter to your Mitsubishi digital AV receiver and will also change inputs to hear the sound from that product. You will automatically hear the high quality digital surround sound from digital products like your HDTV receiver and DVD and high quality analog stereo or surround sound from non-digital products like your VCR.

Special setups: A/V equipment:

VCR connections from pages 10 or 11, Audio Video Connections. Do not connect these cable to the TV, instead connect these to the digital AV receiver to the inputs labeled:

VCR 1 on digital AV receivers model M-VR800 or M-VR1000

VCR on digital AV receivers model M-VR700 or M-VR900

DVD with component video cables from page 14. Connect the video cables as shown, except, do not connect the audio cables to the TV. Instead, connect the digital output connection on the DVD player to the digital input on the back of the digital AV receiver, for example to DIGITAL INPUT 1. If your DVD player does not have component video cables, then use a S-video cable, do not use a regular yellow video cable.

HDTV receiver from pages 15-17. Connect the video cables as shown, except, do not connect the audio cables to the TV. Instead, connect the digital output connection on the HDTV receiver to the digital input on the back of the digital AV receiver, for example to DIGITAL INPUT-2.

AV Receiver from page 13. Connect as shown (use a S-video cable in step 1 if your VCR is a S-video VCR). Make sure to connect the TV outputs to the AV receivers input marked TV.

AUTO STANDBY:

ON (see the owner' guide of the AV receiver for this procedure).

DIGITAL INPUT ASSIGNMENT FOR DVD:

Assign the digital input you used for your DVD player to the AV receiver's DVD input selector. For example, if you connected your DVD player's digital output to the DIGITAL INPUT 1, you need to then assign DIGITAL INPUT 1 to the AV receiver's DVD input, so that it will automatically be used. This procedure is explained in the owner's guide for the AV receiver.

DIGITAL ASSIGNMENT FOR HDTV:

For Mitsubishi AV receiver model M-VR800 or M-VR1000, assign the HDTV digital input to VCR 2. VCR 2 will now be used to hear the HDTV sound.

If you have a Mitsubishi AV receiver model M-VR700 or M-VR900, assign the HDTV digital input to CABLE/DBS, which will be used to hear HDTV sound.

Infrared Emitter from page 13. Connect as shown.

Mitsubishi Home Theater IR System Control using Infrared Emitter, continued

Special setups: TV

Menu selection for AV connections pages 32-34

TV Speakers: **Off**

AV Receiver: **Mits A** (if you have Mitsubishi AV receiver model M-VR800 or M-VR1000)

Mits B (if you have a Mitsubishi AV receiver model M-VR700 or M-VR900)

Audio Output: **Fixed**

Remote Control, pages 21-22

Set the slide switch to the TV position and follow the programming instructions using the AV receiver code 010.

Always point the remote at the AV receiver when you wish to adjust the volume or mute the sound.

Operating the system:

Power ON and watch TV

Turn on the TV to any channel on Ant-A or Ant-B. The AV receiver automatically turns on and selects the TV as the sound source (this may take up to 15 seconds for the complete power on cycle). As you change channels the AV receiver sound will be from Ant-A or Ant-B. Point the remote at the AV receiver to adjust the sound.

Watch HDTV

Change the TV input to DTV to watch your HDTV receiver, the AV receiver will automatically change to VCR 2 (models M-VR800 or M-VR1000) or CABLE/DBS (for models M-VR700 or M-VR900) and the digital sound will be from the HDTV receiver. Refer to the HDTV receiver owner's guide for operating instructions.

Watch VCR

Change the TV input to INPUT-1 to watch your VCR. The AV receiver will automatically change to VCR or VCR 1 and the sound will be from the VCR. Refer to the VCR owner's guide for operating instructions.

Watch DVD

Change the TV input to INPUT-3/DVD component to watch your DVD player. The AV receiver will automatically change to DVD and the digital sound will be from the DVD player. Refer to the DVD owner's guide for operating instructions.

Watch TV again or other equipment connected to INPUT-2 or INPUT-4

Change the TV input back to Ant-A or B or change to INPUT-2 or INPUT-4. The AV receiver will automatically change to TV and the sound will be from Ant-A or B or equipment directly connected to INPUT-2 or INPUT-4.

Power OFF

Return the TV input to Ant-A or B then turn the TV off. The AV receiver will turn off automatically five minutes after the TV turns off. (Do not leave the TV on INPUT-2 or INPUT-4 for more than five minutes when there is no signal coming to these inputs from other equipment. The AV receiver will turn off if it does not receive a TV signal for more than five minutes).

Front Control Panel Functions

VS-50805, WS-55805 and VS-60805

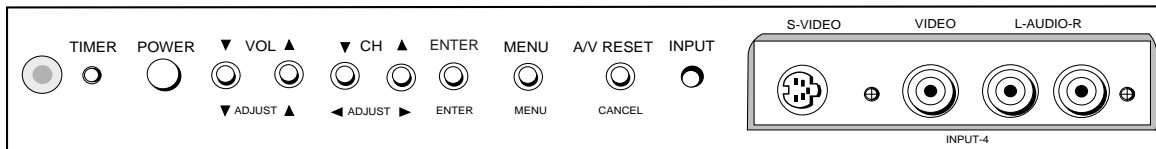

You can use ADJUST, ENTER, MENU and CANCEL found below the buttons to change settings, while in the menus

WT-46805, WS-55905, WS-65905 and WS-73905

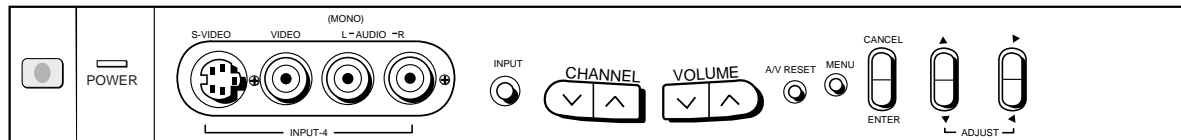

Front Control Panel Functions, continued

Many remote control buttons are duplicated on the front control panel. Adjust, Cancel, Enter, Menu, Power, Volume, Channel and Input operate the same way, using either remote control or front panel buttons. These buttons are explained in the Remote Control Functions section of this Owner's Guide.

POWER

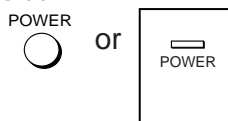

Turns the TV on or off. The green timer light (models VS-50805, WS-55805 and VS-60805) or power light (models WT-46805, WS-55905, WS-65905 and WS-73905) shines steadily when the power is on.

IRIS™

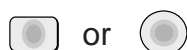

Intelligent Room Illumination (light) Sensor. Turn this feature on or off using the VIDEO button on your remote. When IRIS is on, your TV will automatically adjust picture contrast and brightness for the best picture based on your room lighting. When on, do not block the sensor, to ensure an optimum picture.

TIMER

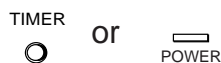

The green timer light (models VS-50805, VS-60805 and WS-55805) or power light (models WT-46805, WS-55905, WS-65905 and WS-73905) will blink when the television is off, if you set the TV to turn on at a specific time (see Timer Menu in the Menu section).

A/V RESET

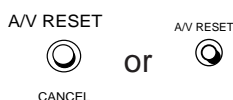

Press this button to reset all seven of the A/V memory categories to the factory default settings (see Audio Video Settings Menu in the Menu section).

VIDEO



Connect the video output of a camcorder or other video device to the TV.

S-VIDEO



Connect the S-video output of a camcorder or other S-video device to the TV. If you connect a S-video cable to this terminal, you cannot use the adjacent VIDEO input.

L-AUDIO-R



Connect the audio output from a camcorder or other device to your TV.

Back Panel Functions

VS-50805 and VS-60805

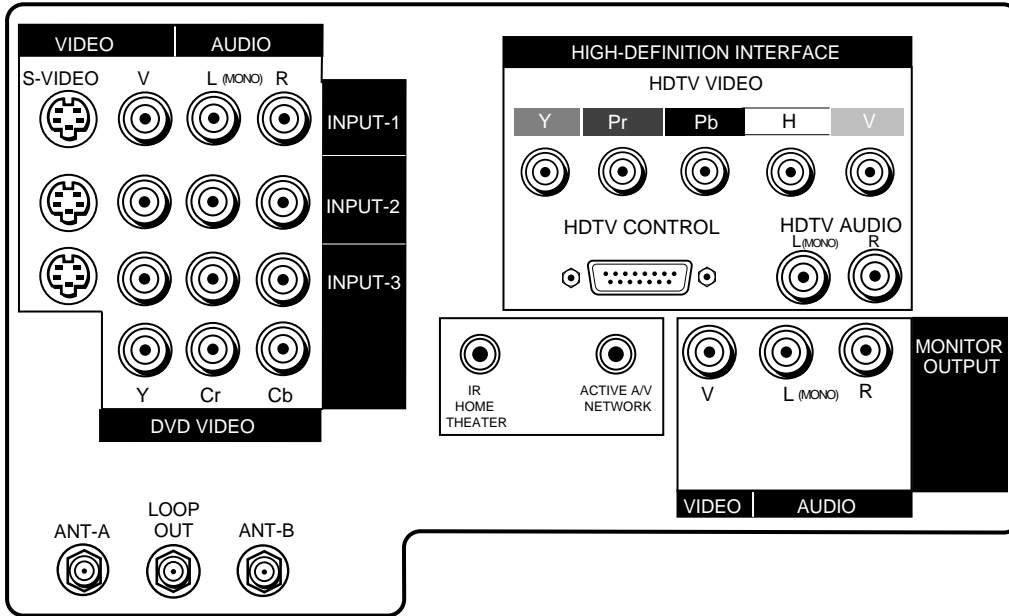

WT-46805, WS-55805, WS-55905, WS-65905 and WS-73905

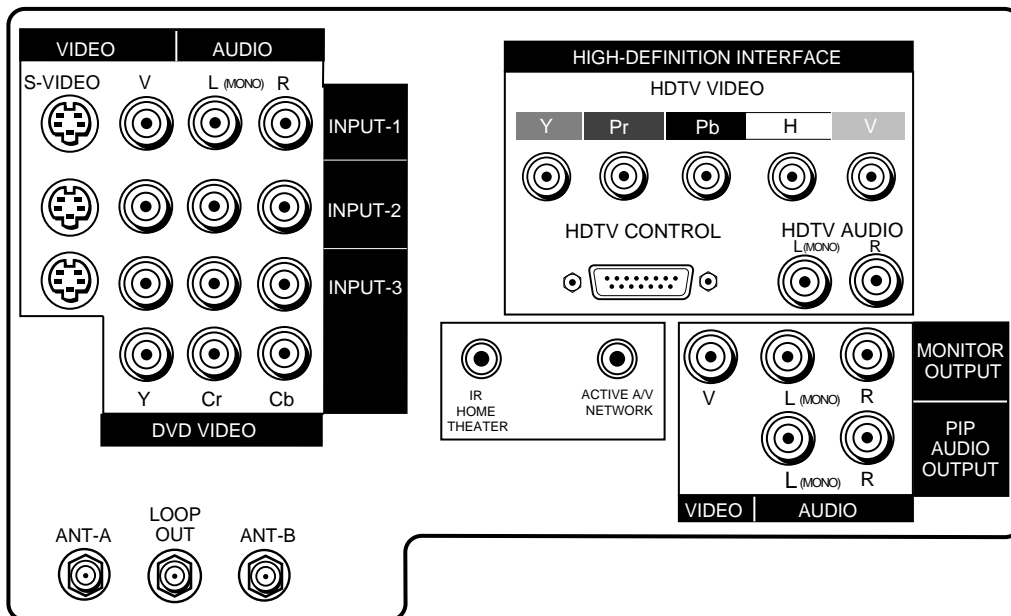

Back Panel Functions, continued

INPUT-1 and 2 S-Video, Video

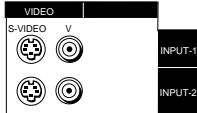

The S-video terminals connect to a S-video signal from a SuperVHS (S-VHS) VCR, laser disc player or other audio video device to the TV. If you connect an input to S-Video, you cannot connect to standard video. For standard video, connect the video output from a standard VCR or other equipment to the video terminals of the TV.

INPUT-1 and 2 audio input

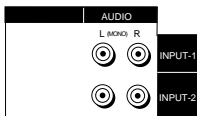

Connect the audio output from a VCR or other equipment to the TV.

INPUT-3, S-Video, Video and DVD component video and audio input

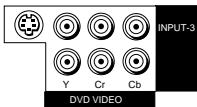

Connect the S-Video or Video the same way as for INPUT-1 and 2. Or, connect the component video (Y, Cr, Cb) and audio signals from a DVD player or other equipment with component video outputs to the TV. If you connect the three component video terminals (DVD VIDEO) and you wish to use the TV's built in speakers, use the adjacent INPUT-3 audio inputs for your audio connection. (For signal compatibility information, see Appendix 3)

If you connect the component video cables you cannot use the S-Video or Video for INPUT-3.

Antenna (ANT-A, LOOP-OUT, ANT-B)



ANT-A and ANT-B receive signals from VHF/UHF antennas or a cable system. LOOP OUT sends the ANT-A signal out to another component (such as a cable box or VCR).

HDTV interface

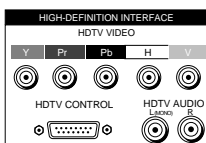

Connect a HDTV receiver to receive digital broadcast signals. The 15 pin HDTV CONTROL connection is used with the optional Mitsubishi HD-I080 receiver.

Some HDTV receivers do not use the H and V terminals. Check your HDTV receiver Owner's Guide for correct connections.

Back Panel Functions, continued

Active A/V Network



Connects Mitsubishi products that have an A/V network terminal.

IR HOME THEATER



Use with the IR emitter (included with this TV) and a Mitsubishi A/V receiver to set up a Home Theater system.

MONITOR OUTPUT



Sends the TV video and audio signals (excluding component video or DTV), to an A/V receiver or other equipment.

PIP AUDIO OUTPUT



For models WT-46805, WS-55805, WS-55905, WS-65905 and WS-73905. Sends the PIP's or POP's audio signal to an amplifier or wireless headphones. If no PIP or POP picture is displayed, then PIP AUDIO OUTPUT will be the same audio as the main TV picture.

Troubleshooting

Problem	Possible Solution
<ul style="list-style-type: none"> The TV remote control doesn't work 	<ul style="list-style-type: none"> Check that the batteries are installed correctly. Check that the select switch is set to "TV". Be no more than 20 feet from the TV when using the remote control.
<ul style="list-style-type: none"> The TV takes several seconds to respond to channel commands 	<ul style="list-style-type: none"> Press ENTER after a channel number to avoid delays. Use the three digit number, i.e. 002 for channel 2.
<ul style="list-style-type: none"> You can't access a channel 	<ul style="list-style-type: none"> Use number keys instead of CHANNEL up/down Be sure the channel you want to view is in memory. Check that the TV is tuned to the correct input source for that channel, by pressing the INPUT button. Make sure the V-chip lock is off (page 44).
<ul style="list-style-type: none"> On-screen displays appear each time you change a function 	<ul style="list-style-type: none"> This is part of normal TV operation.
<ul style="list-style-type: none"> You can't program the TV to turn on automatically 	<ul style="list-style-type: none"> The TV may be locked. Clock is not set..
<ul style="list-style-type: none"> There's no sound even when the volume is turned up 	<ul style="list-style-type: none"> Check to see if the MUTE button is on. The TV's "Listen to:" setting may be set to SAP Check that "TV Speakers" setting is ON.
<ul style="list-style-type: none"> You forget your parent lock passcode 	<ul style="list-style-type: none"> See "Bypassing the Parent Lock, Appendix 3", page 81
<ul style="list-style-type: none"> PIP does not display a picture 	<ul style="list-style-type: none"> Make sure the V-chip lock is off. Not all inputs can be displayed as a PIP. See page 60 for exceptions.
<ul style="list-style-type: none"> The sound doesn't match the screen picture 	<ul style="list-style-type: none"> The TV's "Listen to:" setting may be set to SAP If using stereo or AV receiver speakers, check input selection on the stereo or AV receiver. If using stereo or AV receiver, check that AUDIO is from MONITOR OUTPUT on TV's back panel.
<ul style="list-style-type: none"> There is a large black or gray rectangle on the screen 	<ul style="list-style-type: none"> The TV closed captioning has been set to "text" mode, but there is no text information being broadcast. Turn Off in the CAPTION menu (page 36).
<ul style="list-style-type: none"> You cannot see a picture when you play a VCR tape 	<ul style="list-style-type: none"> If you connected your VCR with A/V cables, use the INPUT button to select the Input source (INPUT-1 or 2) that the VCR is connected to. Make sure Video Mute is turned off.
<ul style="list-style-type: none"> Cannot see a picture when using a non-HD-1080 receiver 	<ul style="list-style-type: none"> If you have previously been using an HD-1080, turn off the power, unplug the set and then plug in and power on TV. Make sure you have connected the HDTV receiver correctly. See connections section in this guide and the HDTV owner's guide.

Important Notes

Warning:

Don't leave stationary or letterboxed images on-screen for extended periods of time. Mix the types of pictures shown.

The normal use of a TV should include a mixture of television picture types. The most used pictures types should fill the screen with constantly moving images rather than stationary images or patterns. Displaying the same stationary patterns over extended periods of time, or displaying the same stationary pattern frequently can leave a subtle but permanent ghost image in your picture. Note that moving images with stationary black bars can also leave a subtle but permanent ghost image. To avoid this, mix your viewing pattern; do not show the same stationary image for more than 15% of your total TV viewing in any one week. Display constantly moving and changing images that fill the screen whenever possible.

This projection television uses picture tubes to project the image to the screen. All picture tubes age with use. As they age, their light output is gradually reduced. Normal television pictures fill the screen with constantly changing images. In these conditions, the picture tubes age at an even rate across the entire screen. This maintains a TV picture that is evenly bright over the whole screen. Stationary images or images that only partially fill the screen (leaving black or colored bars to fill the screen), when used over extended periods of time or when viewed repeatedly, can cause uneven aging of the phosphors and leave subtle ghosts of the stationary images in the picture.

Uneven picture tube aging is not covered by the warranty.

Still or stationary images may be received from broadcasters, cable channels or satellite channels, DVD discs, video tapes, laser discs, on-line services or web/internet searching devices, video games and digital television tuner/converter boxes. Examples of these types of image can be, but are not limited to the following:

- **Letterbox top/bottom black bars**
(These are the black bars shown at the top and bottom of the screen when you watch a widescreen movie on a standard TV)
- **Side bar images**
(These are the solid bars shown on each side of the image when you watch a normal TV program on a widescreen TV)
- **Stock-market report bars**
(These are the row of stock prices normally shown at the bottom of the screen during a financial report)
- **Shopping channel logos and pricing displays**
(Especially bright displays that are shown constantly or repeatedly in the same place on the screen)
- **Video game patterns or scoreboards**
- **Bright station logos**
(Subtle, low-contrast logos are less likely to cause uneven aging, especially if they are translucent and are not always projected in the same spot)
- **On-line (internet) web sites**
or other computer style images that are not changed or are left on display for long periods of time

Important Notes, continued

Warning:

If you place speakers next to the TV, make sure they are magnetically shielded. Ordinary speakers will cause distortion in the picture due to their strong magnets. This distortion, however, will not permanently harm the picture tubes.

If you place non-shielded speakers next to the TV, they may affect the convergence. If this happens, move the speakers further away from the television.

For maximum enjoyment and safe operation of your Mitsubishi TV, please read *IMPORTANT SAFETY-GUARDS*, pages 5 and 6 of your Owners Guide, very carefully and apply them properly.

Cleaning:

Normally, light dusting with a non-scratching duster will keep your TV clean.

If you want to wipe down your TV, turn it off and unplug it. Then, wipe it gently with a soft cloth slightly moistened with water. You can add a few drops of mild liquid detergent to the water for oily dirt.

DO NOT allow liquid to enter the TV through the ventilation slots.

DO NOT use strong or abrasive cleaners.

DO NOT use spray liquids or cleaners directly on the TV's surface.

DO NOT scrub or rub the TV harshly. Wipe gently.

If Service is Required

If you are unable to correct a problem with your TV, consult your Mitsubishi dealer or Mitsubishi Authorized Warranty Service Center.

DO NOT adjust any controls not described in this owner's guide.

DO NOT remove the protective back cover of this unit.

If you see the following display on your screen, you should not change any settings. This is a special display used by the factory. Turn the TV off to remove this menu.

If any settings are changed, your warranty may be void.

NOTE: "Versions" are included for reference only and will vary from those shown below.

If this display appears, make sure that all of the on/off settings are the same as the illustration below and then turn the TV off. If any of the settings are different from the illustration below, turn the TV off and consult your Mitsubishi dealer or Mitsubishi Authorized Warranty Service Center.

Initial	
E2RESET	
Direct Key Mode:	Off
DTV Port:	Auto
DTV Signal Strength:	Ø
Power Restore:	Off
V-Chip Supported:	On
Convergence Reset	
DTV Diagnostics	
DTV E2 Reset	
Free Run:	
Main Version:	V16.....
Sub Version:	V16.....

For further assistance, please call 800-332-2119

Appendix I- Diamond Shield™

The custom-fitted Diamond Shield is an extra protection for your television screen. It has a subtle tint that enhances picture contrast. It can be removed or installed, according to your preference.

Wear cotton gloves to prevent putting fingerprints on the Diamond Shield.

Removal of the Diamond Shield:

- to **remove** put a small piece of masking tape on the outward side of the Diamond Shield. This will designate the special scratch resistant side for later use
- remove the retaining clips (2) with a small, flat blade screwdriver. Press blade into opening at end of clips (Illustrations 1 or 2) and pry out
- after loosening retaining clip ends, gently pull out to remove clips
- gently pull Diamond Shield towards you, bowing the shield out of its locking channels (Illustration 3 or 4)
- reinstall the retaining clips (2), if desired

Installation of the Diamond Shield:

- remove the retaining clips (2) with a small, flat blade screwdriver. Press blade into opening at end of clips (Illustrations 1 or 2) and pry out
- after loosening clip ends, gently pull out to remove clips
- Bow Diamond Shield towards you and insert into locking channels (Illustrations 3 or 4)
- press in provided retaining clips (2) into place at ends first, then towards center
- your Diamond Shield is now installed

IMPORTANT

Store your Diamond Shield™ carefully so that the shield does not become scratched.

Appendix I- Diamond Shield™, continued

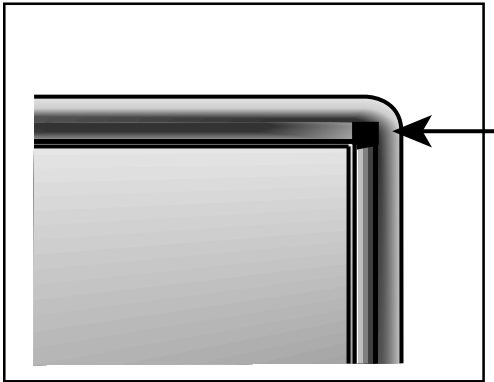

Illustration 1
WT-46805, WS-55905,
WS-65905 and WS-73905

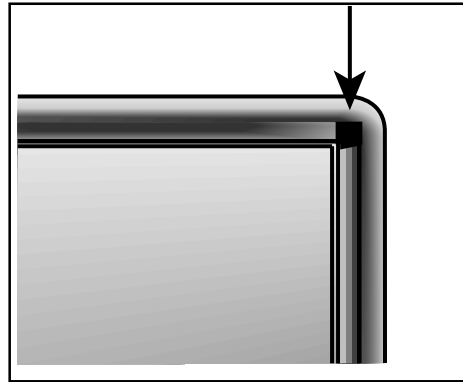

Illustration 2
VS-50805, WS-55805
and VS-60805

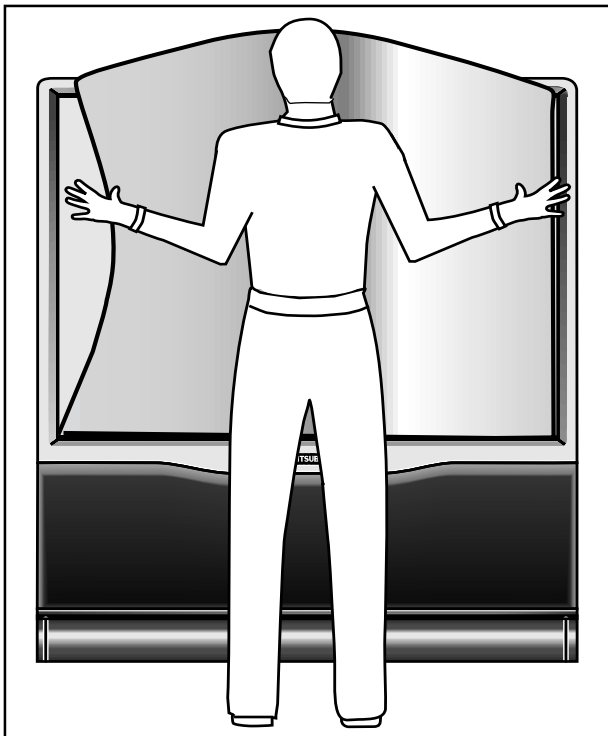

Illustration 3
VS-50805, WS-55805 and WS-60805

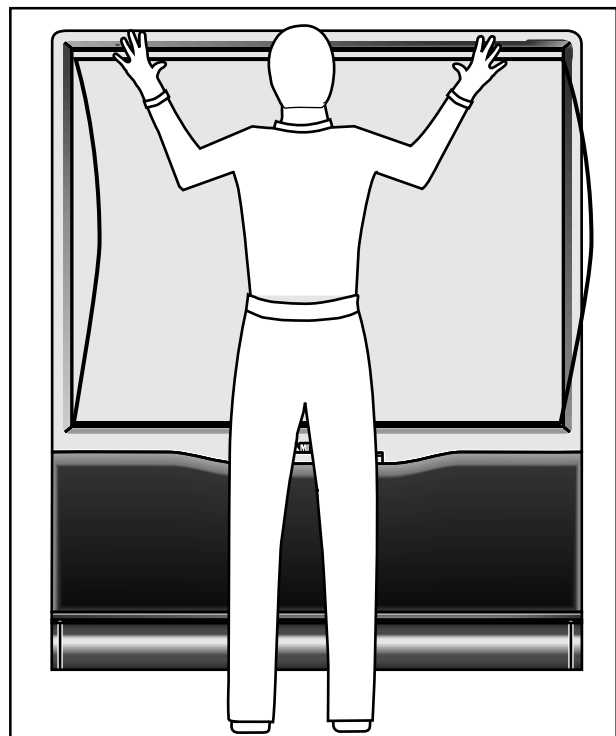

Illustration 4
WT-46805, WS-55905, WS-65905 and
WS-73905

Appendix 2 - Remote Control Programming Codes

See pages 19-20 for instructions on applying these codes

AV Receiver

Mitsubishi	010, 011, 012, 013, 014, 015
Admiral	220
Aiwa	225, 226
Denon	234, 235, 236
Fisher	204
Gerrard	213
Harman Kardon	215
Jensen	223
JVC	232, 233
Kenwood	200, 208
Magnavox	227, 228
Marantz	224
Mclintosh	216
Nakamichi	206, 217
Onkyo	209, 214
Optimus	203, 227, 231, 230
Panasonic	219, 218, 221
Philips	223
Pioneer	205, 207
Quasar	219, 218, 221
RCA	203, 205, 227, 231, 230
Sansui	203, 211, 239
Sharp	234, 237
Sony	222
Sound-sigh	238
TEAC	212, 213, 210, 211
Technics	221, 218, 219
Victor	232, 233
Yamaha	201, 202

DVD

Mitsubishi	003
Denon	250
Ferguson	251
GE	251
JVC	257
Normande	251
Panasonic	250
Philips/Magnavox	258
Pioneer	252
RCA/Proscan	251, 256
Saba	251
Sony	254
Thomson	251
Toshiba	253
Yamaha	250
Zenith	259

Satellite Receiver

Mitsubishi	
HD/Satellite Recvr	173
Echostar	175
G.E.	176
Hitachi	173, 181
Hughes	173
Panasonic	174
Philips	171, 172
Primestar	178
RCA	176, 179, 180
Sony	177
Toshiba	170
Uniden	171, 172

Cable

ABC	124
Archer	132, 125
Cableview	105, 132
Citizen	122, 105
Color Voice	128, 129, 130, 106, 107
Comtronics	128, 129, 130, 106, 107
Curtis	112, 113
Diamond	124, 132, 125
Eagle	129
Eastern	134
GC Brand	132, 105
GE	111, 112, 113
Gemini	122, 143
General Instrument/Jerrold	111, 119, 124, 125, 126, 127, 120, 121, 122, 123
Hamlin	140, 141, 142, 145, 118, 112
Hitachi	103, 124
Macom	103, 104, 105, 108
Magnavox	128, 129, 130, 106, 107, 133, 138
Memorex	130
Movietime	132
Oak	139, 137, 102
Panasonic	109, 110, 114
Paragon	117
Phillips	128, 129, 130, 106, 107, 133, 138
Pioneer	101, 116
Pulsar	105, 132
Puser	132
RCA	115
Realistic	132
Regal	112, 118, 140, 141, 142, 145
Regency	134
Rembrandt	137, 132, 105, 138
Samsung	105
Satellite	100
Scientific Atlanta	111, 112, 113
Signature	119, 124, 125, 126, 127, 120, 121, 122, 111
SL Mark	105, 101
Sprucer	105, 110
Starcom	119, 124, 125, 126, 127, 120, 121, 122, 111
Stargate	132, 105
Televue	101, 105
Texscan	144
Tocom	135, 136
Toshiba	104
Unika	132, 125
United Artists	139, 137, 102
United Cable	119, 124, 125, 126, 127, 120, 121, 122, 111
Universal	122, 132
Videoway	106
Viewstar	129, 130
Zenith	117, 100

Appendix 2 - Remote Control Programming Codes, continued

VCR

Mitsubishi	001, 060, 067, 068, 061, 062, 002
Admiral	055
Aiwa	047, 052
Akai	049, 034, 035, 036
Audio Dynamic	059, 031
Bell & Howell	025, 033
Broksonic	040, 046
Canon	043, 045
Citizen	026
Craig	025, 049, 026
Curtis Mathes	065, 044, 047
Daewoo	063, 021, 044, 079
DBX	059, 030, 031
Dimensia	065
Emerson	023, 038, 039, 040, 045, 046, 062, 063,
Fisher	025, 028, 029, 027
Funai	047, 046, 040
GE	057, 065, 044
Go Video	057, 069, 070, 071
Goldstar	026
Hitachi	043, 065, 020
Instant Replay	044, 043
Jensen	059
JVC	059, 030, 031, 054, 076, 077
Kenwood	059, 030, 026, 031
LXI	047, 026, 020, 027, 028, 025, 029
Magnavox	051, 043, 044
Marantz	059, 030, 031
Marta	026
Memorex	044, 029
MGA	058, 060, 067, 068, 061, 062
Minolta	020, 065
Multitech	067, 047, 024
NEC	059, 030, 031, 054
Olympic	044, 043
Optimus	048, 041, 055, 026
Orion	046, 040
Panasonic	043, 044, 041, 042
Penney	044, 020, 065, 025, 059, 030, 031
Pentax	020, 031, 065
Philco	051, 044, 047, 043, 046, 040
Philips	051, 043, 044
Pioneer	043
Proscan	065, 020, 043, 044, 051, 066, 021, 022
Quasar	041, 042, 043, 044
Radio Shack	053, 044, 025, 056, 029, 060, 047
RCA	053, 065, 020, 043, 044, 049, 051, 066, 021, 022
Realistic	044, 025, 056, 029, 060, 047
Samsung	057, 022, 024, 053
Sansui	059, 046, 040, 072
Sanyo	025, 029
Scott	021, 022, 024, 029, 058, 060, 067, 068, 046, 040
Sears	025, 026, 027, 028 020
Shaintom	037
Sharp	055, 056
Signature 2000	047, 055
Singer	037
Sony	048, 049, 050, 073, 074, 075
SV2000	047
Sylvania	051, 043, 044, 047
Symphonic	047
Tashiro	026
Tatung	059, 030, 031
TEAC	059, 030, 047, 031
Technics	032, 041, 042, 043, 044
Teknika	044, 047
Toshiba	021, 066
Totevision	026
Vector Research	031
Wards	055, 056, 029, 064, 026
Yamaha	025, 059, 030, 031
Zenith	064



Appendix 3 - Bypassing the V-Chip Parent Lock

Cut along dotted line and file after reading.











After you set the lock, you will need your passcode in order to:

- view a V-Chip locked program
- view the locked TV
- cancel the lock
- enter the locked menus

If you forget your passcode, you can view the locked TV without entering your passcode. To do this, simply press the buttons on your remote labeled “9” and “QV” at the same time when your passcode is requested. Unlocking the TV this way is temporary.

If entering the V-Chip Parent Lock menu, then “9” and “QV” will delete your old passcode and pressing  or  will permanently turn off the lock.

To change or permanently cancel the V-Chip Parent Lock:

1. Turn on your TV. If the TV requests your passcode, press  and  at the same time.
2. Press  to view the main menu, then select the ADVANCED FEATURES Menu (see page 26). Press .
3. Use the ▲ or ▼ to select “V-Chip Parent Lock” and press .
4. The on-screen display will ask for your current passcode. Press  and  at the same time.
5. The on-screen display will now ask you to enter a new passcode:
 - To cancel the passcode permanently, press  or .
 - To change to a new passcode, use the number buttons to enter a new code, then press .

IMPORTANT

When changing or deleting your passcode, you must use the remote control included with this TV. You cannot use a remote control from another Mitsubishi component and you cannot use “Universal” remotes from other manufacturers.

This page is blank

Appendix 4 - INPUT-3 Video Connection Compatibility

INPUT-3 Component Video connection compatibility

This input is compatible with component video signals from standard DVD players and other equipment that send standard NTSC component video, also known as 480i. This input may also be compatible with some newer DVD players, that are described as 480p or progressive scan. Since the industry standard concerning copy protection for 480p DVD signals was not finalized when this TV design was completed, you may experience a small amount of picture disturbance near the top edge when playing discs using the 480p outputs of some DVD players.

Input levels and timing with component video

Y = 1.0V p-p (includes sync) 75 ohms

Cr = 700mVp-p, 75 ohms (can also receive signals from outputs labeled R-Y and Pr).

Cb = 700mVp-p, 75 ohms (can also receive signals from outputs labeled B-Y and Pb).

HIGH DEFINITION INTERFACE HDTV Video connection compatibility

This input is fully compatible with the Mitsubishi HD-1080 HDTV receiver. You will need BNC-to-RCA adaptors for the RGB with H and V cable connections to the TV. Adaptors are available at most electronic and computer supply stores.

For other HDTV receivers, this input is compatible with most standard HDTV receivers that have component video outputs. Compatible DTV signals are SDTV 480i or 480p and HDTV 1080i. All other digital TV signals, such as 720p, need to be converted by the HDTV receiver to any of the above signals. Please check the HDTV receiver specifications before connecting.

This input is also compatible with HDTV receivers using RGB with “sync on green” or RGB with “separate H and V sync”. Compatible DTV signals are SDTV 480i, 480p or HDTV 1080i. All other digital TV signals, such as 720p, need to be converted by the HDTV receiver to one of the compatible signals. Industry standards for DTV RGB signals systems, synchronization and signal strengths are not currently established. These inputs will not be compatible with all HDTV receivers that offer RGB. If your HDTV receiver offers both HDTV component video signals and HDTV RGB signals, Mitsubishi suggests you use the HDTV component video signals. Please check the HDTV receiver specifications before connecting.

Input levels and timing when used with HD component video signals

EIA - 770.3 standard levels and timing

Y = 1.0Vp-p (includes sync), 75 ohms

Pr = 700mVp-p, 75 ohms

Pb = 700mVp-p, 75 ohms

H = not used

V = not used

Input levels and timing when used with RGB

G (Y) = 1.0Vp-p 75 ohms (compatible with sync on green)

R (Pr) = 700mVp-p, 75 ohms

B (Pb) = 700mVp-p, 75 ohms

H = 3Vp-p \pm 1.0v, 75 ohms (when using separate H and V sync)

V = 3Vp-p \pm 1.0v, 75 ohms (when using separate H and V sync)

This page is blank

Index

A

Adjusting the picture 56
Adjusting the sound 57–58

B

Back panel functions 70–72

C

Cleaning 75
Codes
 AV receiver 22, 79
 Cable box 21
 DVD player 22, 79
 Satellite receiver 21, 79
 VCR 21, 80
Connection of TV and cable to
 HD-1080 Receiver 15
 HDTV Receiver 16
 HDTV receiver with component video 16
 HDTV receiver with RGB 17
Connection of TV to
 Active A/V network 12
 Antenna or wall outlet cable 9
 AV receiver 13
 Cable box 9
 DVD with component video outputs 14
 Infrared emitter (IR) for home theater control 13
 Stereo audio system 12
 VCR and antenna wall outlet cable 11
 VCR and cable box 10
Connectors for TV and Cable to HDTV receiver 15

D

Diamond Shield removal and installation 77–78

F

Front control panel functions 68–69

H

Home Theater IR system 66–67
Hookup, choosing 7

I

Important safeguards 5
Input-3 video compatibility 83

M

Menu
 Advanced features 28, 41–52
 Antenna selection 38
 Assign input 35
 Audio 54–55
 Audio output 34
 AudioVideo settings 53
 Audio/Video settings 28
 AV connection 32
 AV memory 53
 AV network 32
 AV receiver 33
 AV reset 54
 Black enhancement 55
 Captions 36–37
 CC background 37
 Channel 38
 Channel edit 38–40
 Clock setting, auto 30
 Clock settings, manual 31
 Convergence 49–51
 DTV channel guide 37
 Language 34
 Main 26
 Memorize 29
 Memorize channels 29, 39
 Name channels 39
 Setup 26, 29–37
 SQV 40
 Timer 41–43
 TV speakers 33
 V-Chip Parent Lock 44–48
 Video 54–55
 Video display 52
 Video mute 52
Menu system, summary 25

P

PIP and POP features 60–62
 Activating 60
 Adjust button use 61
 Audio output 62
 Changing channel 61
 Exchanging with main picture 62
 Input 60, 61
 Pausing 61

R

Remote Control
 Active AV Network 65
 Channel selection 23
 Functions 18
 Operating 20
 Other audio and video products 21
 Sleep timer 24
 Special Functions 59

S

Screen formats 63–64
Service required 76
Setup 26
Shortcuts 8
Sleep Timer
 Canceling 24
 Setting 24
Slide switch for A/V components 22
Special features summary 7
Stationary pictures warning 74

T

Troubleshooting 73

U

Unpacking your TV 7

V

V-Chip Parent Lock
 Bypassing 81
 Lock by time system 48
 Lock menu 47
 Passcode bypassing 48
 Passcode setting 44
 Rating information 45–46
 Start time 47
 Stop time 47

**MITSUBISHI
PROJECTION TELEVISION
LIMITED WARRANTY**

MITSUBISHI DIGITAL ELECTRONICS AMERICA, INC. ("MDEA") warrants to the original purchaser of this television that if purchased from an authorized MITSUBISHI Audio/Video Dealer, should it prove defective by reason of improper workmanship and/or material:

a. **Parts.** The lenticular (i.e. front picture) screen and/or the DiamondShield™ is warranted against defects in materials and workmanship for a period of 30 days. All other parts are warranted for a period of one year from the date of the original purchase at retail. We will repair or replace, at our option, any defective part without charge for the part. Parts used for replacement are warranted for the remainder of the original warranty period.

b. **Labor.** For 30 days after the original purchase at retail, we will repair or replace, at our option, the lenticular screen if it proves defective. For all other parts, we will provide the labor for a warranty repair by an authorized MITSUBISHI service center without charge for one year from the date of original purchase at retail.

c. **Notice.** To obtain warranty service, you must notify an authorized MITSUBISHI service center of any defect within the applicable warranty time period.

I. TO OBTAIN WARRANTY SERVICE:

a. Contact your nearest authorized MITSUBISHI service center whose name and address can be obtained from your MITSUBISHI dealer or by writing or calling MDEA at the address and telephone number provided below.

b. Warranty service will be provided in your home or, if required, at an authorized service shop, provided that your television is located within the geographic territory customarily covered by an authorized MITSUBISHI service center. If not, you must either deliver your television to an authorized service location at your own expense, or pay for any travel and/or transportation costs the service center may charge to and from your home. Actual service labor will be provided without charge.

c. Proof of purchase date from an authorized MITSUBISHI dealer is required when requesting warranty service. Present your sales receipt or other document which establishes proof and date of purchase. THE RETURN OF THE OWNER REGISTRATION CARD IS NOT A CONDITION OF WARRANTY COVERAGE. However, please return the Owner Registration Card so that we can contact you should a question of safety arise which could affect you.

2. THIS WARRANTY DOES NOT COVER damage caused by: modification, alteration, repair or service of the product by anyone other than an authorized MITSUBISHI service center; physical abuse to, or misuse of, the product; operation in a manner contrary to the instructions which accompany the product, including uneven picture tube aging and imprinted images on the viewing screen; freight damage; or any damage caused by acts of God such as lightning or fluctuation in electrical power. This warranty also excludes all costs arising from installation, adjustment of user controls, external antenna systems, service of products purchased or serviced outside the U.S.A., initial technical adjustments (set-up) and user-required maintenance. Consult the operating instructions furnished with the product for information regarding user controls.

3. ANY EXPRESS WARRANTY NOT PROVIDED HEREIN, AND ANY REMEDY WHICH, BUT FOR THIS PROVISION, MIGHT ARISE BY IMPLICATION OR OPERATION OF LAW, IS HEREBY EXCLUDED AND DISCLAIMED. THE IMPLIED WARRANTIES OF MERCHANTABILITY AND OF FITNESS FOR ANY PARTICULAR PURPOSE ARE EXPRESSLY LIMITED TO A TERM OF ONE YEAR.

4. UNDER NO CIRCUMSTANCES SHALL MDEA BE LIABLE TO PURCHASER OR ANY OTHER PERSON FOR ANY INCIDENTAL, SPECIAL OR CONSEQUENTIAL DAMAGES, WHETHER ARISING OUT OF BREACH OF WARRANTY, BREACH OF CONTRACT, OR OTHERWISE.

5. Some states do not allow limitations on how long an implied warranty lasts, or the exclusion or limitation of incidental, special, or consequential damages, so the above limitations or exclusions may not apply to you.

6. This warranty gives you specific legal rights, and you may also have other rights which vary from state to state.

7. BEFORE REQUESTING SERVICE, please review the instruction booklet to insure proper installation and correct customer control adjustment. If the problem persists, contact your nearest MITSUBISHI Dealer for name(s) of authorized MITSUBISHI Service Center(s). If you are unable to obtain this information, please call 800-332-2119, or write us at the address below.

MITSUBISHI DIGITAL ELECTRONICS AMERICA, INC.
9351 Jeronimo Road
Irvine, CA 92618-1904



RETAIN THIS PORTION FOR YOUR RECORDS

SERIAL NO. _____

MODEL NO. _____

DEALER NAME _____

STREET ADDRESS _____

CITY _____ STATE _____ ZIP _____

PHONE () _____ PURCHASE DATE _____ / _____ / _____

MO DAY YR



MITSUBISHI DIGITAL ELECTRONICS AMERICA, INC.

9351 Jeronimo Road
Irvine, CA 92618-1904